

EVO-C / EVO-R

COMPACT AIR HANDLING UNIT



ECO
DESIGN

aera.com.tr





AERA has been founded in 2016 by national and international partners to be an important player in HVAC industry with its young but experienced spirit, innovative product design, sustainable quality control and assurance system and advanced logistics. AERA aims to present products and solutions to meet the increasing demand on energy efficiency and human comfort.

AERA is located in Izmir with its production facilities and R&D center of excellence and in Istanbul with its Sales Office. The efficiency and the effectiveness of the manufacturing is ensured with modern production and IT systems. All production processes are monitored with intensive quality control processes in accordance with the national and international regulations and norms to ensure the quality of the end product and overall efficiency.

MAIN PRODUCT GROUPS

- Modular Air Handling Units
- Compact Air Handling Units
- Heat Recovery Ventilators
- Ventilation Units with Heat Pump
- Water Terminal Units (Fan Coils)
- Chillers



EVO Compact units are highly energy efficient, fully automated, quiet and plug-and-play air handling units. It is produced in two models, EVO-C using counter-flow heat exchanger and EVO-R using rotary heat exchanger.

EVO-C Compact Air Handling Units with Counterflow Exchanger;

- 6 different product types in the range of 300-8500 m³/h airflow
- Extremely high aerodynamic efficiency thanks to improved fan / motor design.
- EUROVENT certified aluminum heat exchanger with up to 90% efficiency (EN308)
- Double skin panels with mineral wool insulation and powder coated external sheet metal/Aluzinc internal sheet metal.
- High thermal insulation and air tightness with unique casing design
- Low internal pressure loss
- State of the art controls
- A maximum of 1000mm depth until unit EVO 45C to pass through doors.
- Standard By-pass ventilation.

EVO-R Compact Air Handling Units with Rotary Heat Exchanger;

- 5 different product types in the range of 1000-14000 m³/h airflow
- Extremely high aerodynamic efficiency thanks to improved fan / motor design
- EUROVENT certified heat exchanger with up to 82% efficiency (EN308)
- Double skin panels with mineral wool insulation and powder coated external sheet metal/Aluzinc internal sheet metal.
- High thermal insulation and air tightness with special casing design
- Low internal pressure loss
- State of the art controls
- Rotor speed control according to temperature differences
- Specially designed gasket construction to reduce leakage
- Condensate, enthalpy and absorption type rotor heat recovery exchangers according to different moisture requirements.
- Optional recirculation part (standard up to EVO-R 40).



All manufacturers are legally obliged to follow ECO-DESIGN directives, which are a set of the European Union’s regulations that state use of energy for energy-consuming products. LOT6 of the directive reviews the ventilation devices and air handling units and is affective in the European Parliament with the EU directive number 1253/2014 and 1254/2014. The ECO-DESIGN directives, prepared by the European Council for the purpose of replacing low energy-efficient products in the market with those of high efficiency, have been accepted as a prerequisite for CE marking with the dates specified and the entry of non-conforming devices into EU countries is prohibited.



Within the scope of the ECO-DESIGN directive, which has been in force since January 1st 2016, a number of sub-limit values have been defined for air handling units, such as fan, heat recovery exchanger and filter efficiency. There are also directives concerning the operation of the air handling unit.

ECO-DESIGN Application Criteria

For which applications does the ECO-DESIGN directive apply?	The Directive has been created for ventilation devices and air handling units where some or all of the air contaminated by human activity or building emissions in the interior is replaced by fresh air from outside.
Device Classification	Residential Ventilation Equipments (RVU) $Q_{max} \leq 250 \text{ m}^3/\text{h}$ Non-Residential Ventilation Devices (NRVU) $Q_{max} > 250 \text{ m}^3/\text{h}$ Residential Ventilation Devices (RVU) * $1000 \text{ m}^3/\text{h} > Q_{max} > 250 \text{ m}^3/\text{h}$
Implementation Schedule	Tier 1: January 1, 2016 Tier 2: January 1, 2018
Unit Exceptions	<ul style="list-style-type: none"> ■ Agricultural ventilation applications ■ Transportation applications ■ Exhaust hoods in industrial kitchens ■ Fresh air or exhaust devices with a power consumption of 30 W or less and a one-way airflow ■ Bi-directional flow devices with a power consumption of 30 W or less for each fan ■ Axial or radial fans in a body according to EU 327/2011 ■ Fans operating in explosive atmosphere ■ Emergency fans ■ Fans operating at very high or very low temperatures

* In cases where the manufacturer states that it is for residential use.

Unidirectional Ventilation Units (UVU)

The model device is defined in the directive as follows.

- Airflow is one-way (supply or exhaust only).
- On the inlet side there is a class F or better filter.
- There are one or more fans in the same air line inside the device.

In the Directive, the limit value for minimum fan efficiency and SFP_{int} is specified as follows.

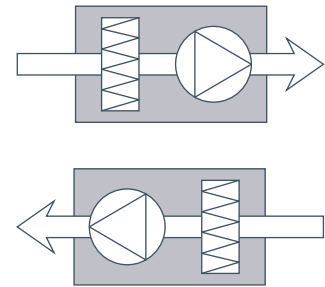

		ErP 2016	ErP 2018
Minimum Fan Efficiency η_s (%)	$P \leq 30$ kW	$6,2 \times \ln(P^*) + 35$	$6,2 \times \ln(P) + 42$
	$P > 30$ kW	56,1	63,1
The maximum allowed SFP_{int} [W/(m ³ /s)] value for the model device		250	230
Variable speed drive requirement		Yes	Yes
Obligation to monitor pressure drop for filters		No	Yes

* Nominal Effective power supply at nominal external pressure and air flow, including electric power supply (kW), fan motors and drives of motors.

Bidirectional Ventilation Units (BVU)

The model device is defined in the directive as follows:

- Airflow is bidirectional (with supply air and exhaust)
- There is a class F on the supply air side and a class M filter on the exhaust side.
- The unit has a heat recovery system.

In the Directive, the limit value for minimum fan efficiency and SFP_{int} is specified as follows:

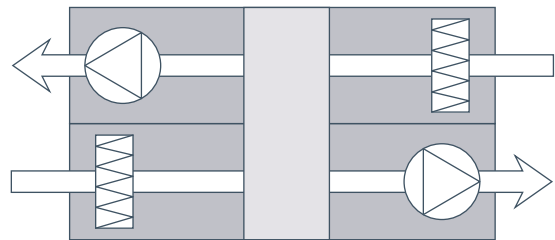

			ErP 2016	ErP 2018
Heat recovery system with thermal by-pass mandatory			Yes	Yes
Thermal Efficiency (EN308)* η_t [%]	Plate / Rotary HR		67	73
Maximum allowed SFP_{int} value for model device	Plate / Rotary HR	$q^{*2} < 2$ m ³ /s	$1.200 + E - 300 \times q / 2 - F$	$1.100 + E - 300 \times q / 2 - F$
		$q \geq 2$ m ³ /s	$900 + E - F$	$800 + E - F$
HR efficiency add-on, E	Plate / Rotary HR		$(\eta_t - 67) \times 30$	$(\eta_t - 73) \times 30$
Filter correction coefficient, F	Model Unit		0	0
	No M filter		160	150
	No F filter		200	190
	No M + F filter		360	340
Variable speed drive requirement			Yes	Yes
Obligation to monitor pressure drop for filters			No	Yes

*1 EN 308 conditions are internal and external weather conditions where condensation has not occurred and should be taken as follows. **OUTDOOR AIR CONDITIONS:** 5 °C **ROOM CONDITIONS:** 25 °C, 28 % RH

*2 Air flow at the working point of the device (m³/s)

SFP_{int} Value and Calculation Method

According to EN 13779, the SFP is calculated as the ratio of the fans of the air supply unit provided by the unit.

In ECO-DESIGN directives, the SFP value is redefined as SFP_{int}. The SFP_{int} value relates to the performance of the components used in the design of the device, and does not add any inefficiencies in the ducting system. This provides a more accurate comparison between units. The internal losses to be taken into account in the SFP_{int} calculation are pressure losses in the heat recovery exchanger, filter and housing.

Sample Calculator: The table below shows the operating point for the internal pressure drops in a heat recovery ventilator. The SFP value is compared with the SFP_{limit} value specified in the ECO DESIGN criteria, calculated by these values and fan efficiencies. If the SFP interior is smaller than the SFP_{limit} the device meets the ECO DESIGN criteria.

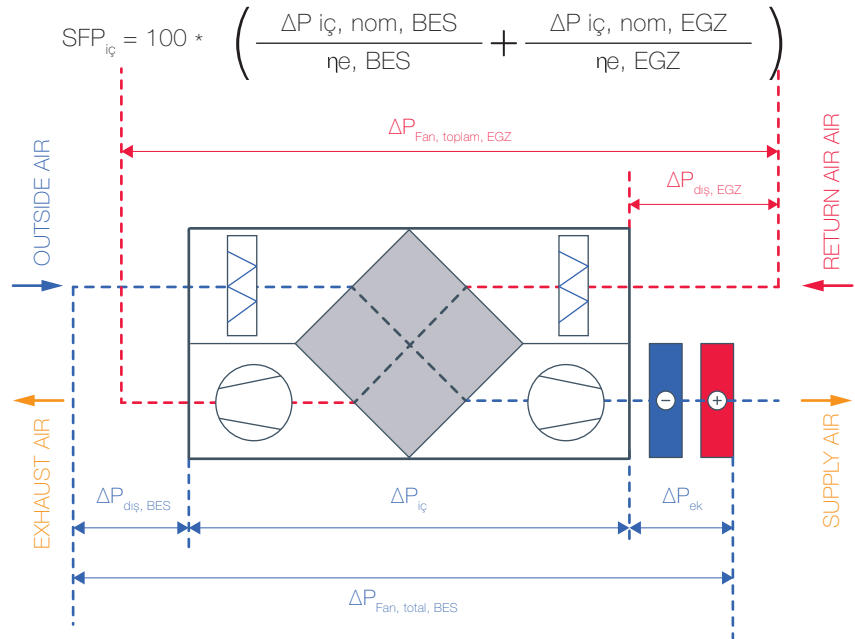

	Intra-device pressure loss [Pa]				External Static pressure (Pa)	Fan efficiency at the operating point (including external static pressure)	SFP _{int}
	HR Exchanger	Supply Air Filter (F7) Exhaust Air Filter (M5)	System Loss	Total			
Supply Air	179	109.97	44.75	333.72	100	0.596	559.9
Exhaust Air	180	90.86	44.75	315.61	100	0.596	529.5
SFP_{int, total}							1089.5

Filter Correction Factor, F	M5 and F7 filter	0
HRE efficiency addition, E	(η _t -0.67)*3000	30
SFP_{ig, limit} (2016)	1200 + E - 300 * q_{nom} / 2 - F	1146.66

Where the ventilation unit is not designed for a single operating point, compliance with the ECO-DESIGN directive should be indicated on the unit operating curves. The following is an ECO-DESIGN performance curve for an air handling unit with variable airflows.

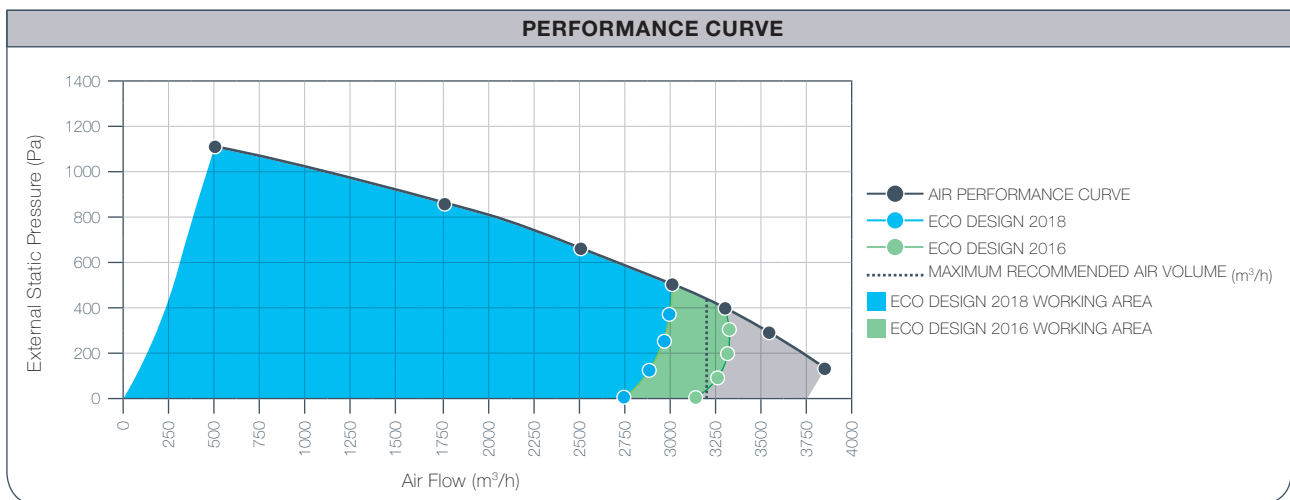

EUROVENT

Eurovent is an organization set up by leading European Air Handling Unit Manufacturers to ensure fair comparison and fair competition. In accordance with the sampling program, the air handling units and components are correctly classified using the performance information obtained in tests conducted in independent test laboratories. At the beginning of the certification program, the unit, which is requested by the certification committee, is produced by the supplier, the unit is sent to the test and the casing and performance values are reported. According to the manufacturer's Quality certificates, the tests are repeated every year or every 3 years. Thus, the accuracy of the catalog data of the products and the results of the selection software are checked within tolerances and an attempt is made to create a trust environment within the market.

ENERGY CLASSIFICATION TABLE				
CLASS	ALL UNITS	UNITS FOR FULL OR PARTIAL OUTDOOR AIR AT DESIGN WINTER TEMPERATURE $\leq 9^{\circ}\text{C}$.		FAN EFFICIENCY LEVEL NGref-class [-]
	VELOCITY class [m/s]	HEAT RECOVERY SYSTEM (HRS)		
		η_{class} [%]	Δp_{class} [Pa]	
A+ / A+↻ / A+↑	1.4	83	250	64
A / A↻ / A↑	1.6	78	230	62
B / B↻ / B↑	1.8	73	210	60
C / C↻ / C↑	2.0	68	190	57
D / D↻ / D↑	2.2	63	170	52
E / E↻ / E↑	No calculation required			Not required

CLASS	CLASSIFICATION SYMBOL	CLASSIFICATION PARAMETERS
Units for full or partial outdoor air at design winter temperature $\leq 9^{\circ}\text{C}$.	A + E	Face Velocity
		Heat Recovery Efficiency
		Heat Recovery Pressure Drop
		Fan Efficiency
Recirculation units or units with design inlet temperatures always $> 9^{\circ}\text{C}$.	A + ↻ E ↻	Face Velocity
		Fan Efficiency
Stand-alone extract air units.	A + ↑ E ↑	Face Velocity
		Fan Efficiency

The following steps should be taken while calculating the class of the air handling unit;

- It is assumed that the air handling unit belongs to a class and the values belonging to this class are noted in the table.
- For the design working point, the fan static pressure increase, external static pressure loss, cross-sectional speed, fan power and, if the unit belongs to subgroup 1, the HRS heat recovery exchanger efficiency and pressure drop are calculated.
- Depending on the velocity, the pressure correction factors ΔP_x is calculated if it belongs to subgroups 1 then ΔP_y and ΔP_z are additionally calculated.
- The reference power consumption (Pair side-ref) for the associated air line (fresh air or exhaust) is calculated.
- Finally, the reference power consumption factor (fs-Pref) is calculated. If this value is equal to 1 or smaller, the unit meets the requirements of the first accepted class. If it is greater than 1, the same procedure should be repeated by adopting a lower subclass.

Pressure correction due to velocity; ΔP_x

$$\Delta P_x = (\Delta P_{s-dahilli} - \Delta P_{s-HRS}) * \left\{ 1 - \left(\frac{V_{sinif}}{V_s} \right)^{1.4} \right\}$$

- $\Delta P_{s-internal}$ = $\Delta P_{s-static} - \Delta P_{s-external}$ internal pressure drop across components; exclusive system effect pressure drops [Pa]
 $\Delta P_{s-static}$ = useful fan static pressure increase measured between fan inlet and fan outlet [Pa]
 $\Delta P_{s-external}$ = external (ductwork system) pressure drop [Pa]
 ΔP_{s-HRS} = HRS pressure drop [Pa] (0 if no HRS or subgroup 2 or 3)
 V_{class} = value from Table 2 [m/s]
 V_s = velocity in AHU filter (fan if no filter) cross section [m/s]

Pressure correction due to HRS pressure drop; ΔP_y

$$\Delta P_y = \Delta P_{s-HRS} - \Delta P_{class}$$

- ΔP_{s-HRS} = HRS pressure drop (0 if no HRS or subgroup 2 or 3) [Pa]*
 ΔP_{class} = value from Table 2 [Pa] (0 if subgroup 2 or 3)

Pressure correction due to HRS efficiency; ΔP_z

$$\Delta P_z = (\eta_{class} - \eta_s + 5 * cf_{heater}) * \left(1 - \frac{mr}{100} \right) * f_{pe}$$

- η_s = HRS dry efficiency winter [%] (0 if no HRS or subgroup 2 or 3)
 η_{class} = value from Table 2 [%] (0 if subgroup 2 or 3)*
 mr = mixing ratio, winter (recirculation air / supply air; maximum), allowed range 0 to 85 [%]
 f_{pe} = pressure – efficiency factor
 = $(- 0.0035 * t_{ODA} - 0.79) * t_{ODA} + 8.1$ [Pa / %]
 t_{ODA} = design outdoor temperature, winter [°C]
 cf_{heater} = correction for electrical heater (reheater, i.e. heater downstream the HRS).
 = 0 when there is no electrical heater
 = 1 when there is an electrical heater
 * (Eğer HRS bilgisi yoksa veya altgrup 2 veya 3 ise 0 alınacaktır)

Fan reference power

$$P_{airside-ref} = \frac{[\Delta P_{s-static} - (\Delta P_x + \Delta P_y + \Delta P_z)] * q_{v-s}}{a * \ln(P_{airside-ref}) - b + NG_{ref}}$$

- $P_{air side-ref}$ = fan reference power [kW] (use $P_{sup-ref}$ for supply air side $P_{ext-ref}$ or extract air side)
 q_{v-s} = air volume flow rate [m³/s]
 NG_{ref} = Fan Efficiency Grade corresponding to the class value (see Table 2)
 a, b = coefficients as per Table 3 below.

$P_{air side-ref}$	a	b
≤ 10 kW	4.56	10.5
> 10 kW	1.1	2.6

Absorbed power factor; f_{s-Pref}

The values from the calculations made in the previous steps are used in the following formula. If the result is less than or equal to 1, the unit meets the requirements of the accepted energy class, otherwise the same procedure must be repeated by adopting a lower subclass.

$$f_{s-Pref} = \frac{P_{s-bes} + P_{s-emş}}{P_{bes-ref} + P_{emş-ref}} \leq 1$$

- f_{s-Pref} = absorbed power factor
 P_{s-sup} = active power supplied from the mains, including any motor control equipment, to selected supply air fan [kW]
 P_{s-ext} = active power supplied from the mains, including any motor control equipment, to selected extract air fan [kW]
 $P_{sup-ref}$ = supply air fan reference power [kW]
 $P_{ext-ref}$ = extract air fan reference power [kW]

VDI 6022

- Sealing materials in air-handling areas shall be closed-pored; they shall not absorb any humidity or release any odours and, in particular, must not provide a nutrient substrate for microorganisms.
- In order to avoid microbiological growth, it must be ensured that the relative humidity is not higher than 80% in areas where filters and silencers are present. Humidifiers must not be placed in front of silencers or filters.
- The materials, the design of surfaces and geometrical shaping of the system components shall be such as to prevent the adhesion and depositing of contaminations.
- All components must be accessible for the purposes of the required inspection and cleaning work
- Ensure that there are no humid areas in the humidifier and cooler outlets during shut downs longer than 48 hours. For this purpose, humidifiers and coolers must be switched off beforehand and dry air should circulate through the system (gradual shut down).
- Units with an inside height of 1.3 m and above are required to have a monitoring glass for all humidifiers, fans and air filters. In addition to this lighting inside is recommended.
- As a matter of principle, only such air filters shall be used for air filtration in ventilating and air-conditioning systems and in air-handling units, which have been tested in accordance with EN 779 or EN 1822, and which are labelled individually
- The drain pan must be made of corrosion-resistant material inclined from each side. The drain line should not be connected directly to the waste water line.
- Air filters should be replaced from dust-filled side. Filters should not be flat on the unit floor. The pouches of the bag filters should always be placed in vertical position.
- Independent of other indicators; Each filter stage of the air handling units in which the volumetric air flow is more than 1000 m³ / h must be fitted with a differential pressure gauge in the correct operating range to instantly show the pressure losses of the air filters.
- If a belt driven fan is used (except flat belts) a filter stage should be added after the fan.

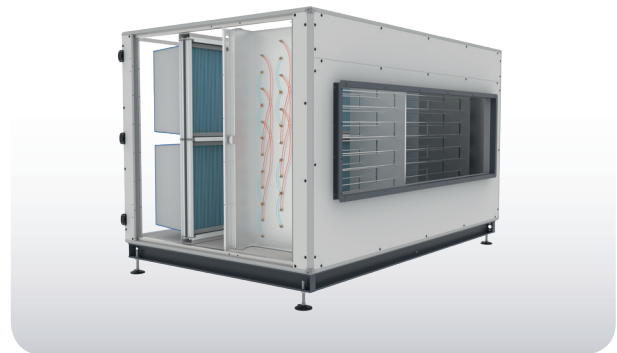
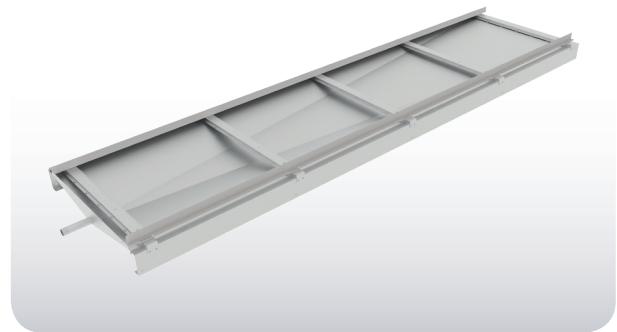

EN 13053

The performance tests of air handling units and components and the classification of velocity, total power consumption and system energy efficiency in the unit are made according to EN 13053 standard.

CLASSES OF AVERAGE AIR VELOCITY LEVELS INSIDE THE CASING			
CLASS	AIR VELOCITY (m/s)		
V1	≤ 1.6	Note: The air velocity in the unit has a large influence on energy consumption. The velocities are calculated for air velocity in AHU cross-section. The velocity is based on the square area of filter section of a unit, or if no filter is installed it is based on the square area of the fan section.	
V2	> 1.6 'den 1.8 'e		
V3	> 1.8 'den 2.0 'e		
V4	> 2.0 'den 2.2 'e		
V5	> 2.2 'den 2.5 'e		
V6	> 2.5 'den 2.8 'e		
V7	> 2.8 'den 3.2 'e		
V8	> 3.2 'den 3.6 'e		
V9	> 3.6		
CLASSES OF POWER INPUT OF DRIVES (FANS)			
CLASS	Pm maximum (kW)		
P1	≤ Pm ref x 0.85	The electrical power consumption depends on the air flow of the fan and the increase in static pressure. Pressure losses in the fan housing and on the diffuser plate are not regarded as static pressure increases, but as fan losses separately.	
P2	≤ Pm ref x 0.90		
P3	≤ Pm ref x 0.95	$P_{m\ ref} = \left(\frac{\Delta P_{stat}}{450} \right)^{0.925} * (q_v + 0.8)^{0.95}$ <p> $P_{m\ ref}$ [kW] reference power input ΔP_{stat} [Pa] sstatic pressure at the fan section q_v [m³/s] air flow </p>	
P4	≤ Pm ref x 1.00		
P5	≤ Pm ref x 1.06		
P6	≤ Pm ref x 1.12		
P7	> Pm ref x 1.12		
HEAT RECOVERY CLASSES			
CLASS	Energy efficiency $\eta_{e1:t}$		
H1	≤ 71	$\eta_e = \eta_t \times \left(1 - \frac{1}{\epsilon} \right)$ <p> η_e [%] Energy Efficiency η_t [%] Thermal efficiency under dry conditions ϵ [-] Performance Coefficient </p>	
H2	≤ 64		
H3	≤ 55	If supply air and exhaust air flows are not equal and no information is available on efficiency, the efficiency is calculated using the following empirical formula.	
H4	≤ 45		
H5	≤ 36		
H6	Hayır		
		$\eta_t = \eta_{t\ 1:t} \times \left(\frac{\text{Exhaust air flow}}{\text{Fresh air flow}} \right)^{0.4}$	

■ The filter pressure losses during design should be calculated by taking the arithmetic mean of the initial and final pressure losses. The final pressure drops according to the filter classes are indicated in the standard with the following values.

G1 - G4: 150 Pa
 M5 - F7: 200 Pa
 F8 - F9: 300 Pa

TEST LABORATORY

The air handling units produced in our company are tested and certified by independent organizations and also subjected to tests in the AERA-ANEMO laboratory in order to carry out the design verification procedures.

The ANEMO laboratory, which is designed in accordance with the European Norms and Directives used, carries out tests according to the following criteria;

- EN 308 Heat exchangers-Test methods for determining the performance of heat recovery devices from air to air and waste gases
- EN 1886 Ventilation for Buildings - Air Handling Units - Mechanical Performance
- EN 13053 "Air handling units - Classification and performance for devices, components and cells"
- EN 13779 "Performance requirements for ventilation and room conditioning systems"
- European Union Energy Commission (EU) No 1253/2014 "ECO-DESIGN requirements for ventilation equipment"
- EN 305 "Performance specifications for heat exchangers and test procedures for performance measurement"
- ISO 5167-4: 2003 "Flow measurement with differential pressure measurement devices placed in circular cross-section pipes - Part 4: Venturi pipes"

For air performance tests, two sealed and isolated volumes are used for indoor and outdoor conditions. The thermal efficiency and capacity tests of air handling units and air performance tests can be carried out in 5200 m³ / h air flow and -20 ° C outside and + 37 ° C indoor conditions.

Advanced air leak measurement stations for body performance tests and precision measurement equipment and data acquisition software for thermal performance measurements such as thermal bridging and thermal permeability are also used.

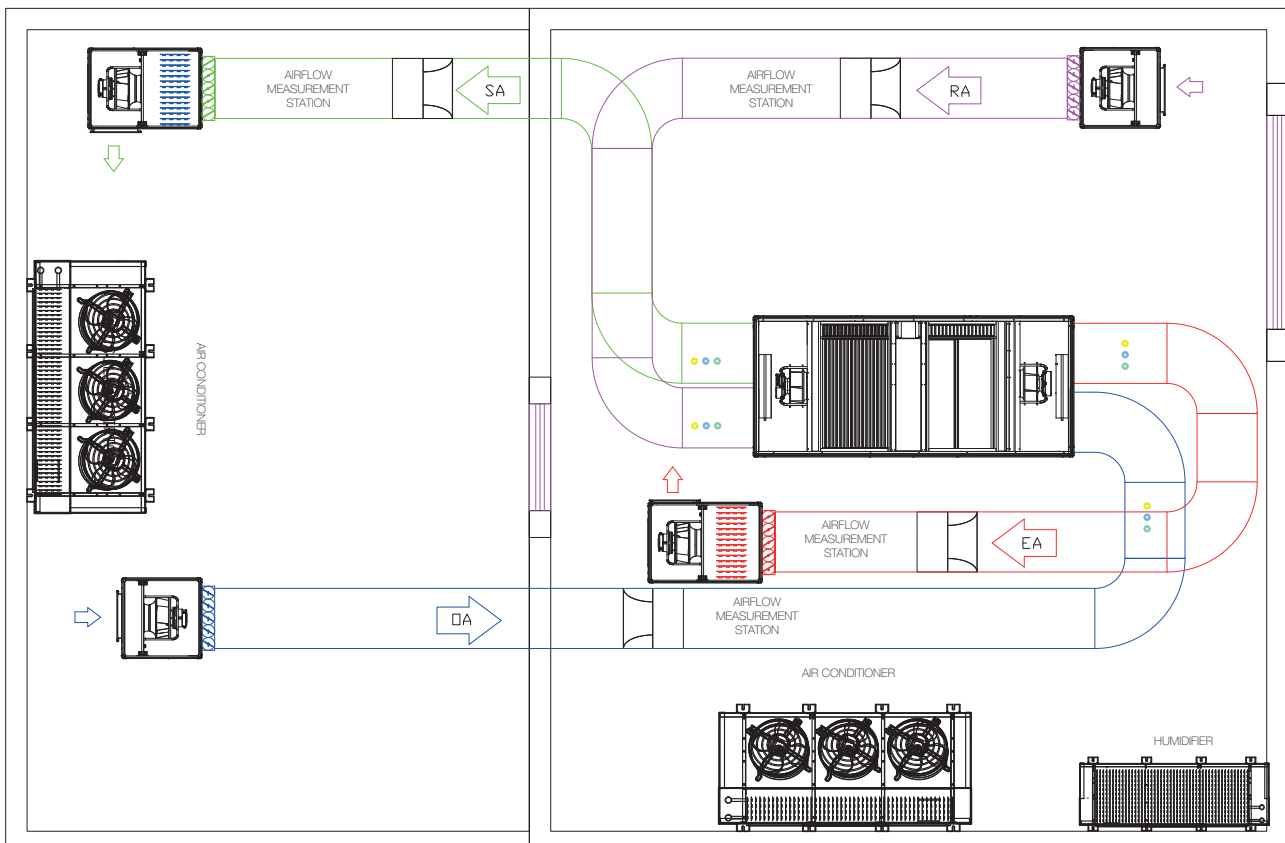

All of the equipment used during the test is periodically checked and calibrated by the accredited institutions. The main test and auxiliary equipment found in the ANEMO laboratory;

- Sensors (Temperature, relative humidity, differential pressure)
- Venturi tube
- Energy analyzer
- Data acquisition device and software
- Leak test system
- Sound measuring station
- Air conditioning system

Selection Software developed by our company is used to provide the supply air conditions and component requirements determined in the projects. The sections containing all the components that may be present in the air handling units are defined in the selection software and are designed according to the configuration desired in the project.

The selection software is web-based, this makes it possible to access it from anywhere with a username and password. Previously made selections are stored in the user specific database, the old projects can be examined and reproduced and used for new projects, if desired, can be sent to another user.

ADVANTAGES OF AERA SELECT

- The calculations for heating, cooling, humidification / dehumidification, sound attenuation, heat recovery, suction or blowing, filtering and air mixing are automatically made with user inputs, the necessary components are selected and the performance values of the EVO Compact Air Handling Units with the details are presented with a report to the user.

- After creating the required configuration from the AERA Selection software, the user can obtain performance values at the new operating points of the unit by simulating the increase / decrease of the external pressure or the air flow by simulating how the device will work at another operating point.

- The physical constraints at the installation site can be defined by selecting the appropriate unit before installation by configuring the program before manufacturing.

- AERA Selection Software contains measures against user-induced selection or configuration errors.

- In addition to the classic belt driven fans, there are also external motor plug fans and direct drive EC plug fans can be easily installed in the Fan Array application, which significantly reduces the unit size, reduces noise levels and simplifies service.

- The selection reports are prepared according to Eurovent criteria and contain all necessary information including energy class. ECO-DESIGN calculations, which have become an important criterion in determining the performance of the device today, are also performed for the selected device, and the values and conformity reached are indicated on the report.

- It has a simple and plain interface that can be easily learned, different units in the project are selected quickly and their technical and price information are reported.

- In addition to the performance values of EVO Compact Air Handling Units, price information are also extracted as proforma invoice from the selection software.

- The detailed technical drawings of the EVO Compact Air Handling Unit selected according to the needs of the project are provided in DXF format.

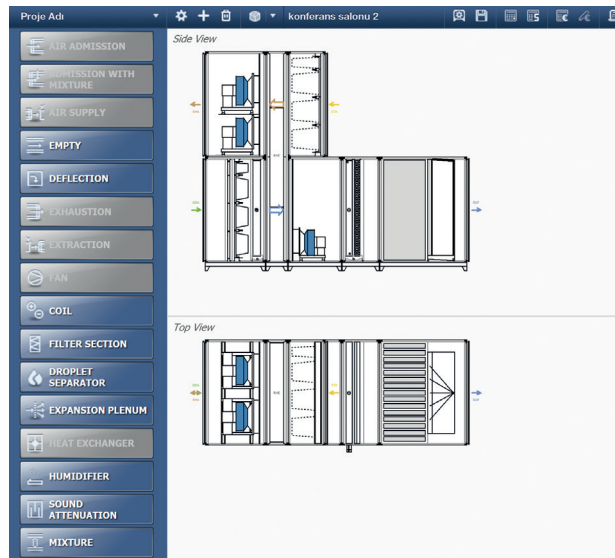
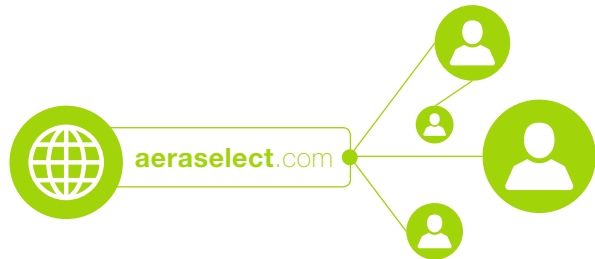

EVO-C FAN PERFORMANCE CURVES

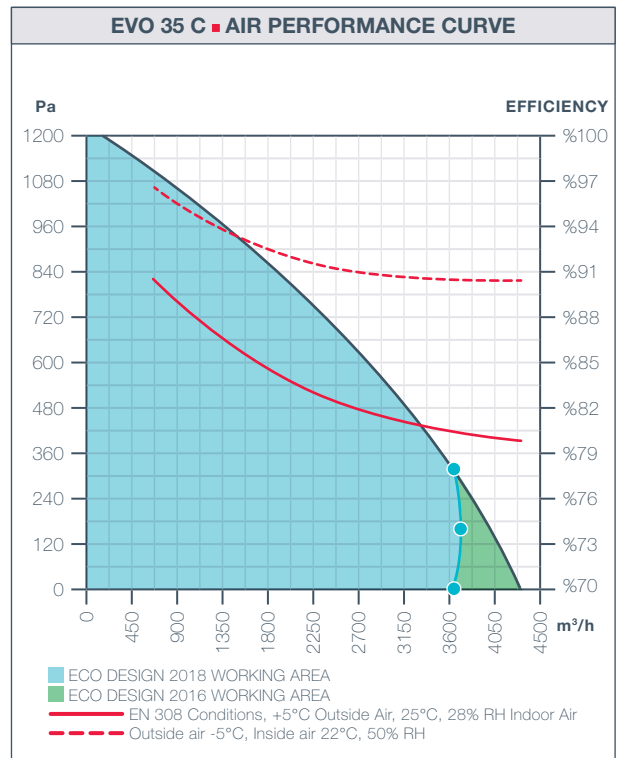
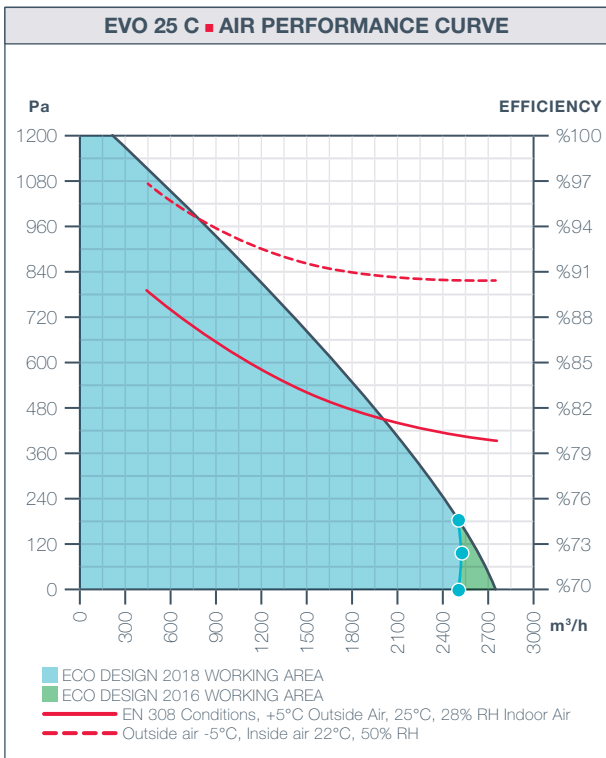
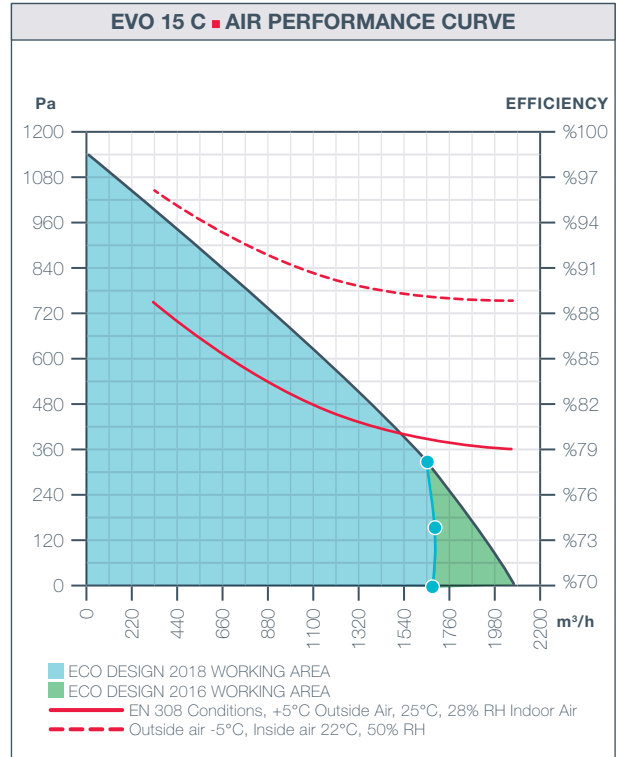
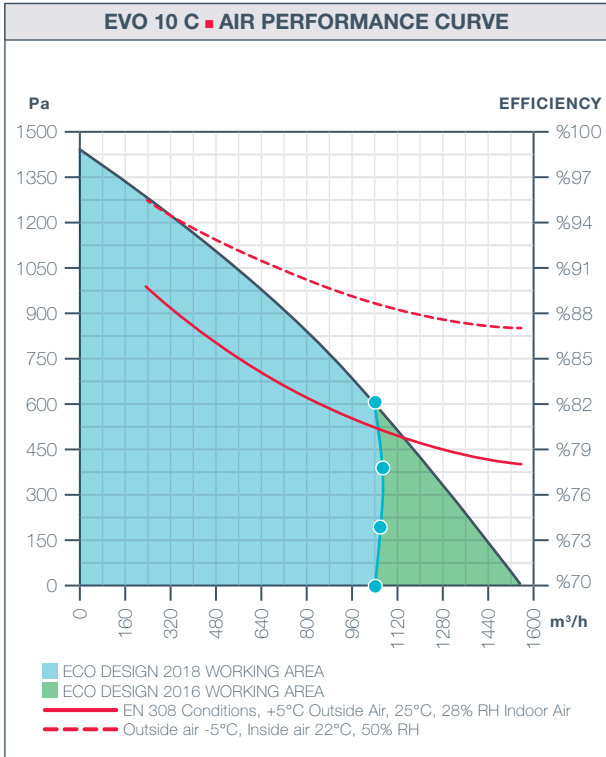

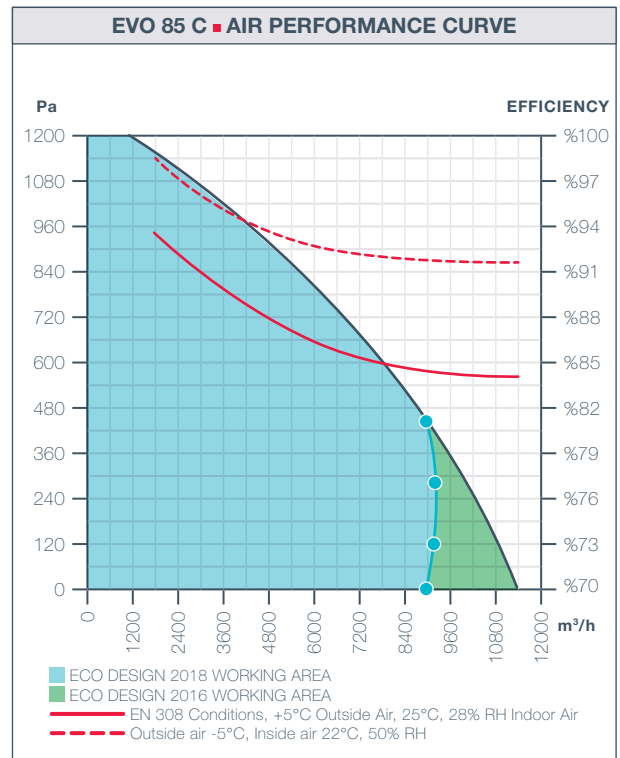
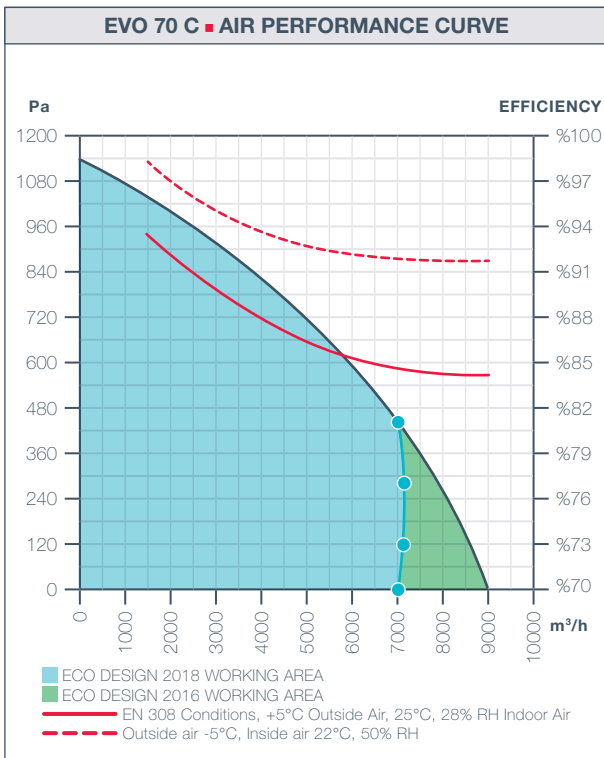
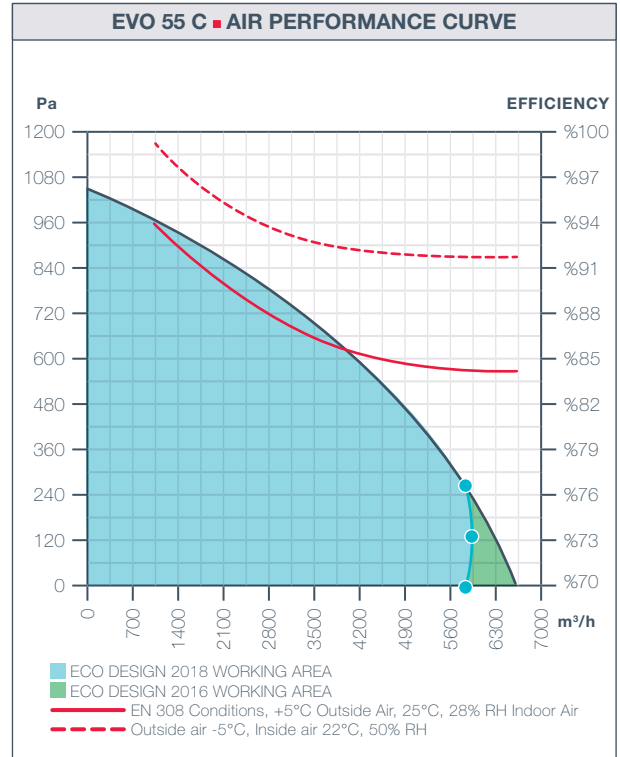
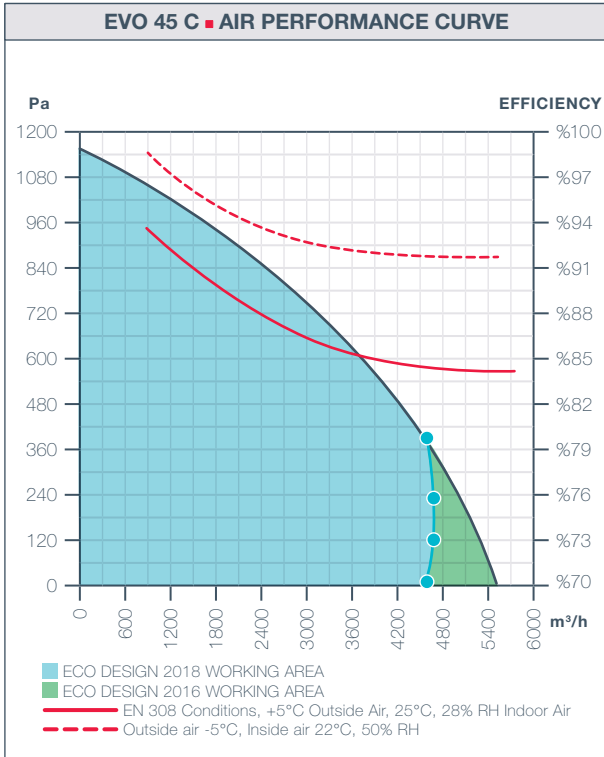

EVO-C TECHNICAL SPECIFICATIONS

MODEL	EVO-C							
	10	15	25	35	45	55	70	85
MAXIMUM AIR FLOW (m ³ /h)	1545	2070	2750	4300	5490	6600	9000	11370
MAXIMUM POWER CONSUMPTION (kW)	1,00	1,04	1,50	2,46	3,40	3,70	5,28	6,90
MAXIMUM CURRENT (A)	4,40	4,60	6,60	3,80	5,20	5,80	8,00	10,60
SUPPLY VOLTAGE	230 V / 50 Hz / 1 ~				380 V / 50 Hz / 3 ~			
FILTER CLASS (EXHAUST/FRESH AIR)	M5/F7	M5/F7	M5/F7	M5/F7	M5/F7	M5/F7	M5/F7	M5/F7
WEIGHT (kg)	190	260	370	435	510	570	640	715
SOUND PRESSURE (dB)	56	54	57	53	58	60	59	61

Sound values are measured for a ducted unit at 250Hz and 1,5m away from the unit.

The filter class is specified according to EN779: 2012 standard.

Max Air Volumes are Indicated according to 0 Pa static pressure loss.

DIMENSIONS

MODEL	DIMENSIONS [mm]				
	L	D	H	AxB	
EVO-C	10	2005	635	1160	315x210
	15	2090	645	1355	350x310
	25	2345	865	1435	470x310
	35	2970	967	1574	580x410
	45	3515	1020	1995	580x410
	55	3555	1230	1995	855x410
	70	3605	1530	1995	1055x410
	85	3655	1880	1995	1200x410

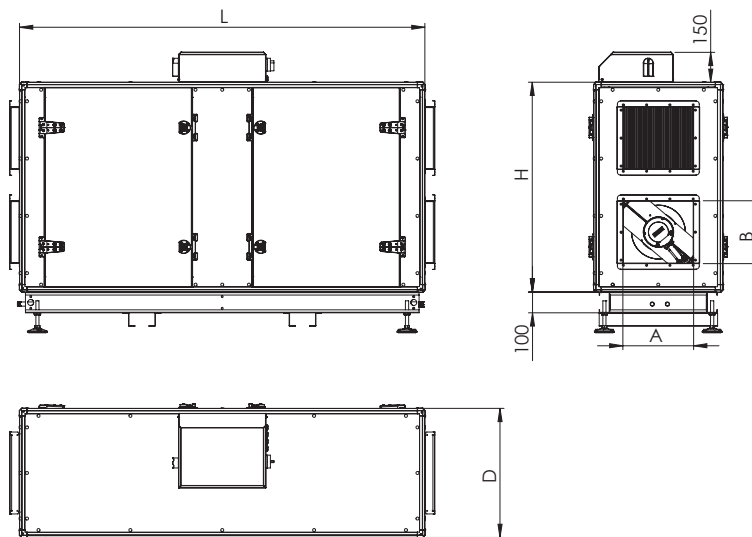

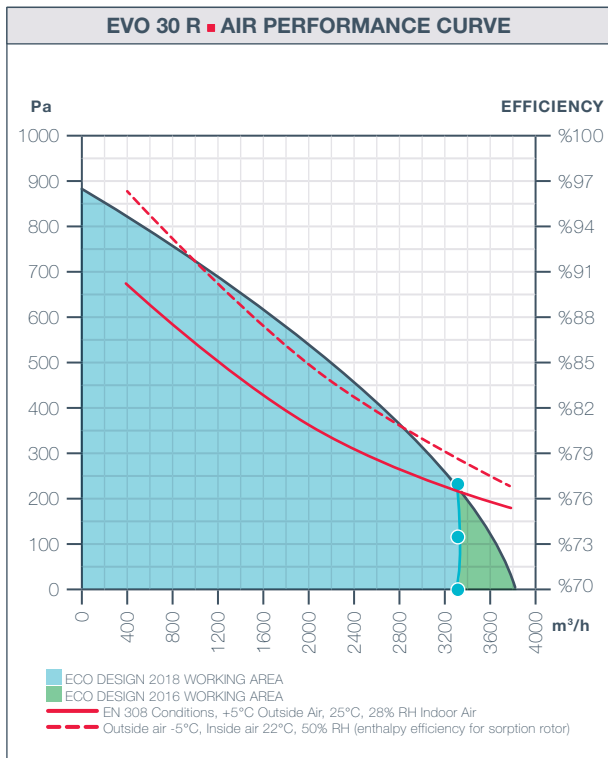
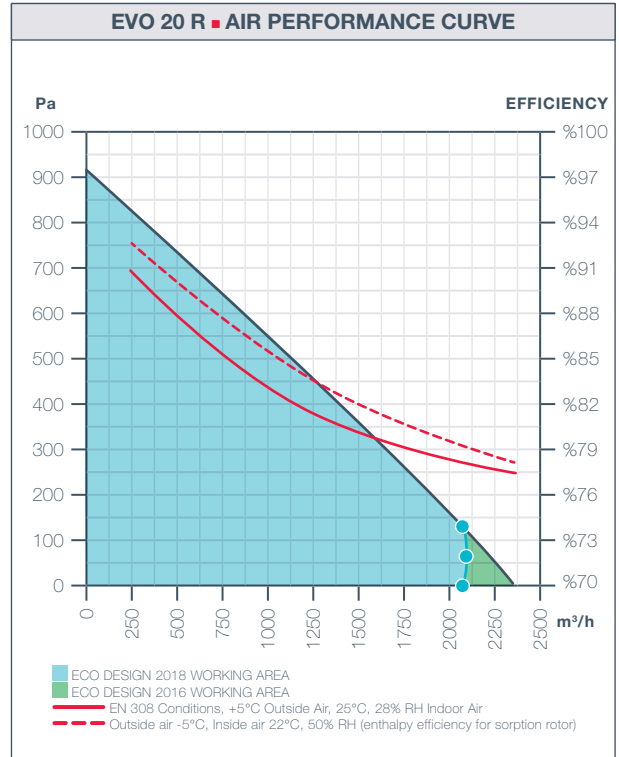
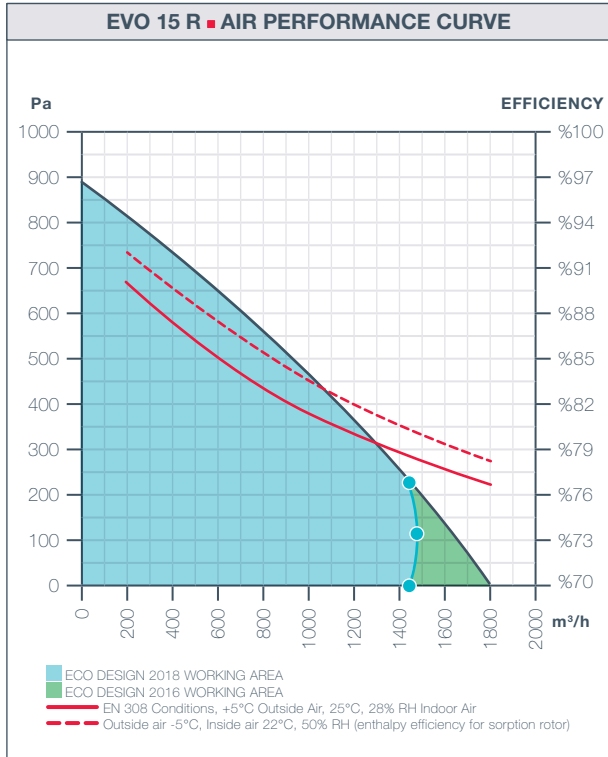

EVO-R PERFORMANS EĞRİLERİ

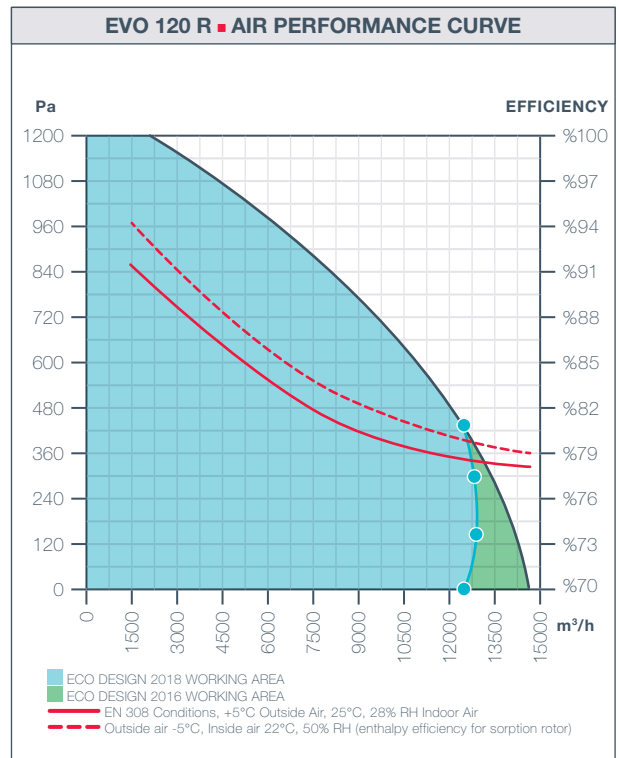
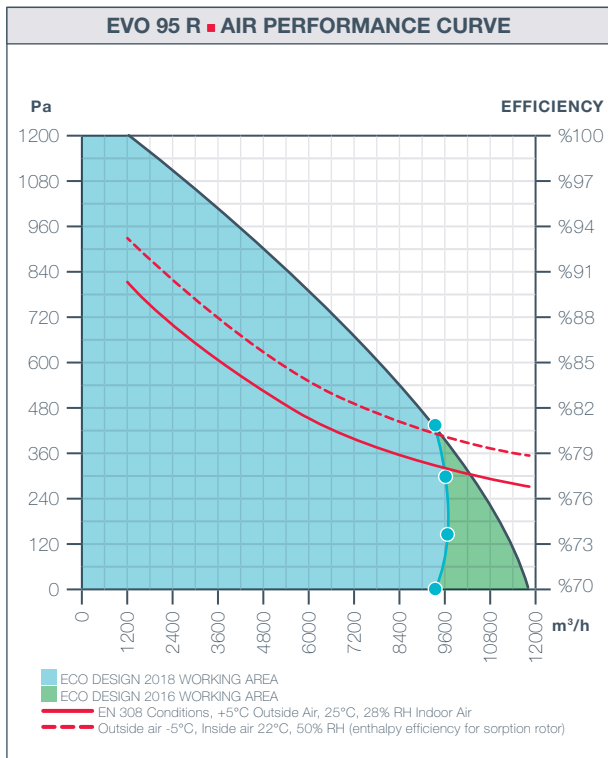
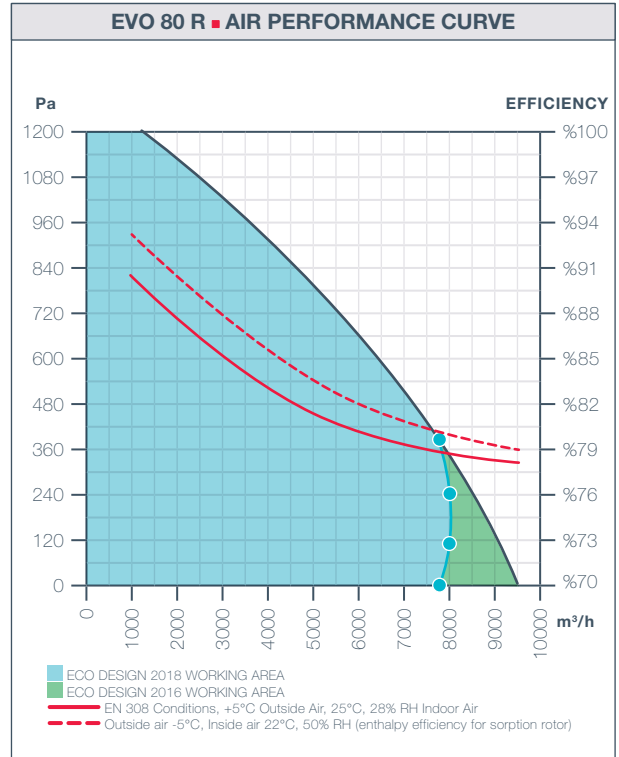
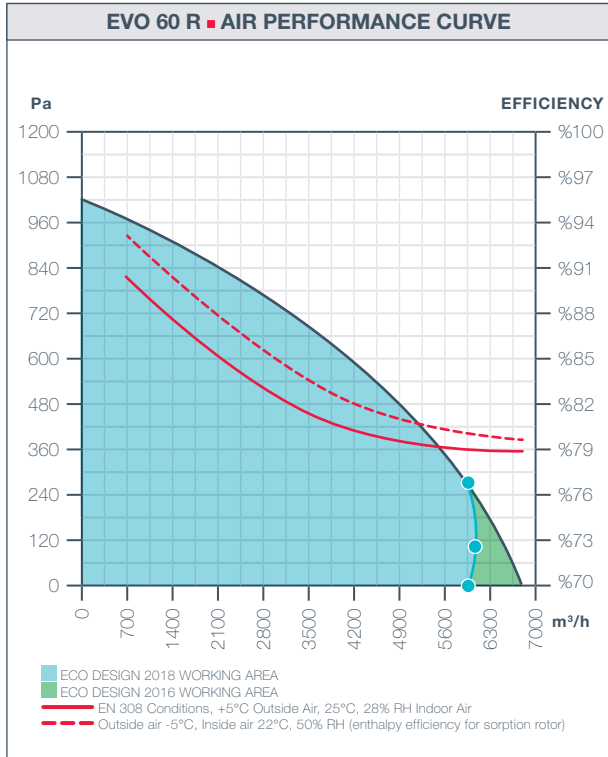

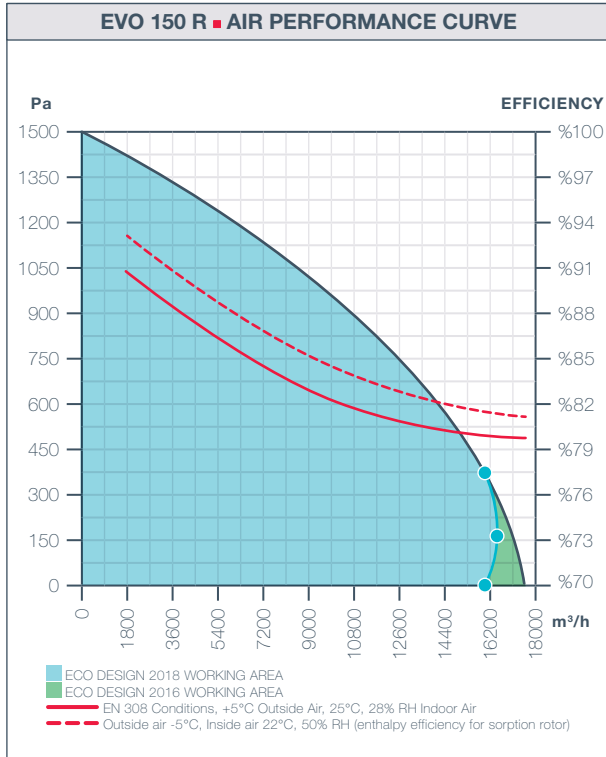

MODEL	EVO-R									
	15	20	30	50	60	80	95	120	150	
MAXIMUM AIR FLOW (m³/h)	1800	2350	3860	5810	6810	9460	11850	14750	17620	
MAXIMUM POWER CONSUMPTION (kW)	0,90	1,00	2,00	3,40	3,70	5,28	6,90	9,40	10,00	
MAXIMUM CURRENT (A)	5,60	4,40	3,26	5,20	5,80	8,00	10,60	14,40	15,40	
SUPPLY VOLTAGE	230 V / 50 Hz / 1 ~					380 V / 50 Hz / 3 ~				
FILTER CLASS (EXHAUST/FRESH AIR)	M5/F7	M5/F7	M5/F7	M5/F7	M5/F7	M5/F7	M5/F7	M5/F7	M5/F7	
WEIGHT (kg)	205	270	340	470	590	720	840	1095	1390	
SOUND PRESSURE (dB)	46	53	55	58	60	59	61	62	58	

Sound values are measured for a ducted unit at 250Hz and 1,5m away from the unit.
 Max Air Volumes are Indicated according to 0 Pa static pressure loss.

DIMENSIONS

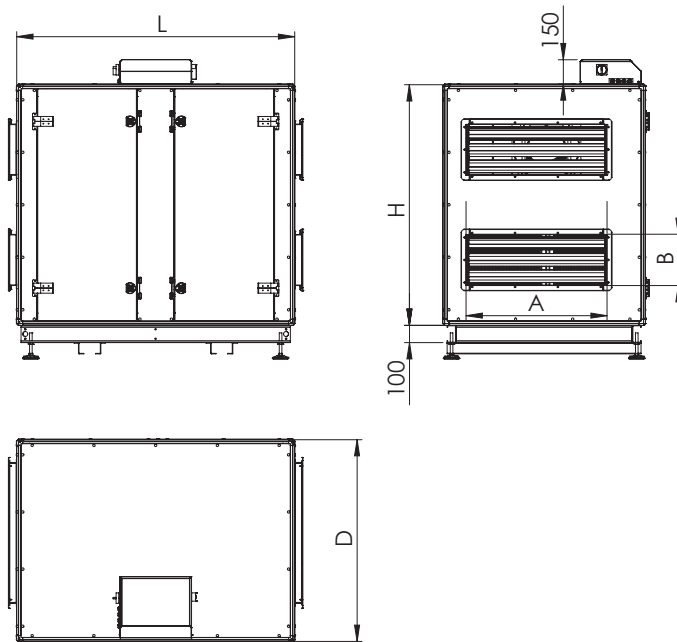

MODEL	DIMENSIONS [mm]				
	L	D	H	AxB	
EVO-R	15	1700	760	1295	350x310
	20	1700	860	1400	470x310
	30	1700	970	1500	580x410
	50	1845	1240	1775	855x410
	60	2015	1360	1895	855x410
	80	2185	1610	2145	1055x410
	95	2315	1710	2245	1200x410
	120	2450	1860	2400	1475x510
	150	2535	2110	2645	1600x710

CASING DESIGN

EVO Compact Air Handling Unit's casings are engineered with today's standards, according to future needs. By eliminating the defects of traditional casings, high thermal and acoustical performance have been achieved, mechanical strength and corrosion resistance have been increased. As a result, a compact body that provides easy operation and service has emerged.

Performance values were calculated prior to the actual product testing, using modern engineering methods developed by 3D computerized design and analysis during design stage. Subsequently, these values were verified with tests made in accordance with relevant standards in our modern testing laboratory.

LOW THERMAL BRIDGING DESIGN

PVC Frame

In EVO Compact Air Handling Units, unique panels with high thermal and air leakage resistance are used in fixed panels and service panels. Continuity is provided in the seals by special corner joining method.

The panels prevent the formation of thermal bridging are made up of sheet metals and sealing gaskets that are fixed on a specially designed PVC frame. Since the inner and outer panel sheets are not connected, thermal leakage from metal surfaces is prevented.

With the help of the PVC frame used, continuous and homogeneous insulation was obtained on the panels. With this structure on the sides of the panel, the thickness remain the same for each surface. The air gap in the PVC profile increases the thermal resistance of the profile and reduces the total heat transfer coefficient.

Unit Components

The components that may cause thermal bridging due to the connection between the inner and outer air flow in the central body are locks and hinges and similar connection components. This connection is evaded by connecting all components externally and a seamless insulation is provided on the casing.

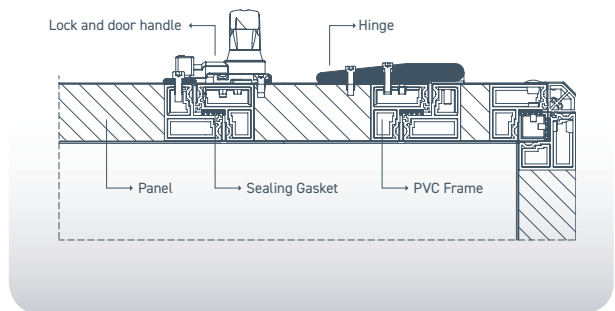
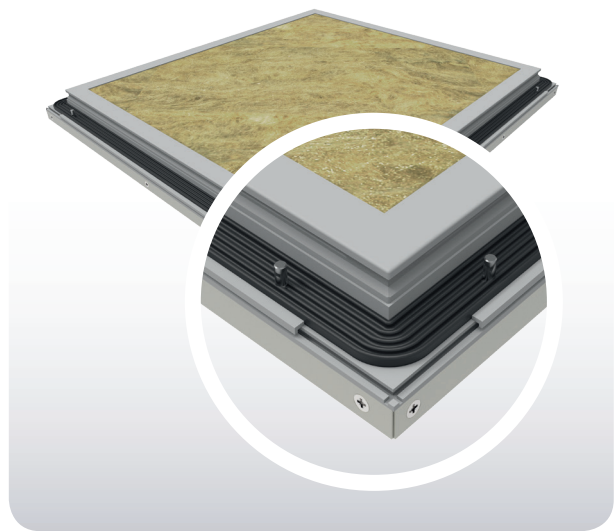
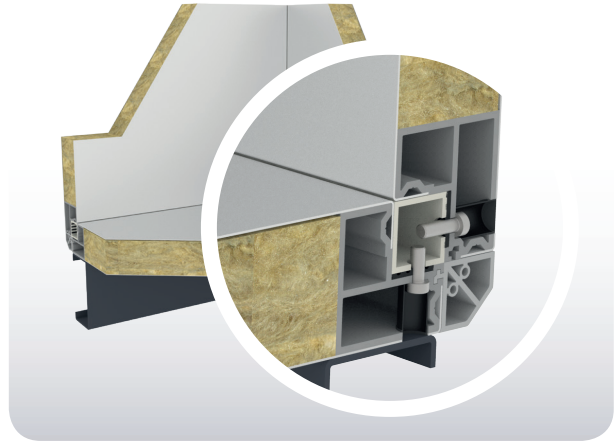

STEEL PROFILE

EVO Compact Air Handling Units have a frame made of galvanized steel profiles with increased corrosion resistance. The steel profile panel is surrounded by PVC profile and sealing gasket to prevent heat and air leaks. A strong and sturdy structure is provided with the steel profile and the strength of the body is also increased.

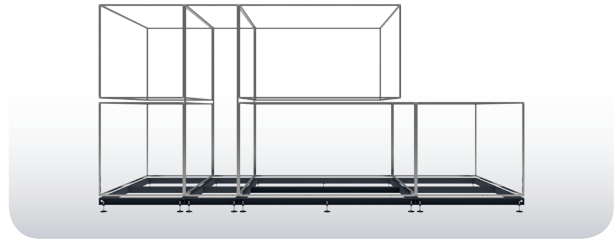

PANEL

Unit's panels are made of sheet metal and 50mm mineral wool insulation. The outer surface is made of polyester painted sheet as the standard, the inner surface and the sheets used for fixing the components are made of Aluzinc coated AZ 150 quality sheet. Both types of steel perform very well in the salt vapor test with the aim of measuring the corrosion resistance and have also been applied in harsh environments.

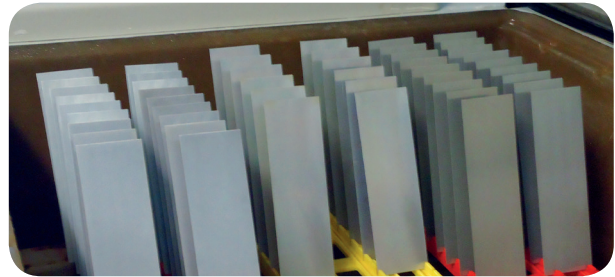

DRAIN PAN

In EVO compact air handling units, cooling coils, plate heat recovery exchanger and humidifier sections are equipped with a drain pan made of stainless steel, which is bi-directionally sloped and sealed. The drain pan and skid components are designed in accordance with VDI 6022 standard and have fast drainage and easy to clean structure.

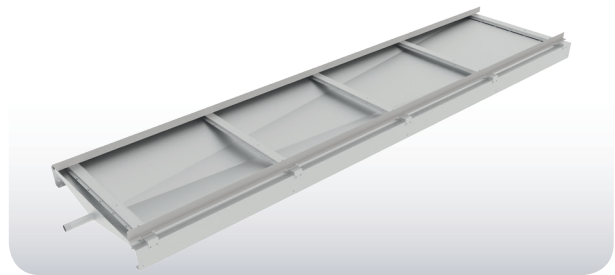

In units where the drain pan is used, one ball siphon is provided as standard with each drain pan. The siphon is designed for both negative or positive pressure. In order to facilitate drainage according to the pressure on the section, it is desirable to have a certain height between the drainage outlet and the waste water connection, which is indicated on the respective cell label. The desired height can be achieved with the help of the adjustable feet.

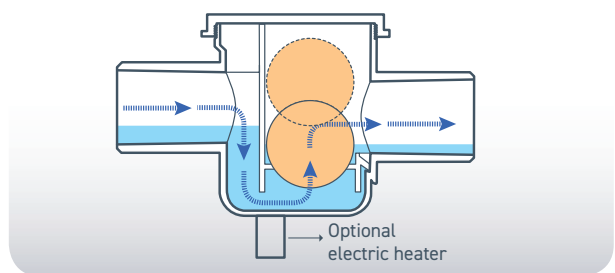

FAN

EVO Compact Air Handling Units are designed using plug type EC fans with high aerodynamic efficiency, low noise levels and low energy consumption. All fans meet ECO-DESIGN criteria set by the Energy Commission of the European Union and are compatible with ERP 2015.

Plug fans with EC motors with the help of SENSO PLUS control system, can be driven steplessly with an indoor air quality sensor or with constant volume. Fans are ready to provide constant pressure in VAV systems with the VAV kit supplied as accessory.

Plug type fans with EC motors are AC-powered fans with DC motor technology. The DC motor provides high electrical efficiency and can be connected to the AC mains with the converter located on them. It is perfectly matched to the high-tech electronic components used and magnetic noise transmitted to the network is prevented.

EC motors communicate with the SENSO PLUS control system via Modbus. This reduces the number of in-line cabling and provides more information to the user and ensures optimum operating point is used in the unit.

The computerized analysis of the fan blades has made it possible to optimize the aerodynamic efficiency and reduce the sound levels. The back plate of the fan impeller has been redesigned for a linear air flow.

The EC motors used perform well beyond today's efficiency requirements and all motors comply with the IE4 energy efficiency class.

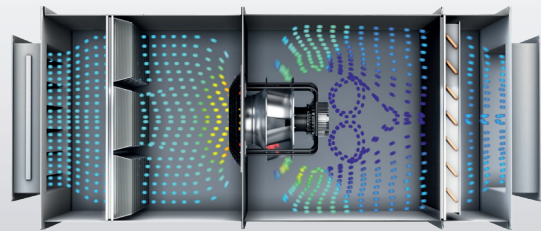

COUNTERFLOW PLATE HEAT EXCHANGER

In EVO-C Compact Air Handling Units, plate type heat recovery exchangers working with counter flow principle are used. Superior energy efficiency and low pressure drops and high total energy efficiency is achieved, and at nominal temperatures the total heat recovery efficiency reaches 93%.

The exchanger, which is made of aluminum plates with high corrosion resistance, provides high sealing between exhaust and fresh air flows.

By-pass dampers are provided as standard. At temperatures where outdoor weather is convenient, fresh air is provided directly indoors without entering the exchanger. With the help of the optional internal air quality sensor, the recirculation function can be activated by turning off the fresh air intake of the device and more energy can be saved.

In EVO-C Compact Air Handling Units, combined type heat exchangers are used to provide compactness for larger air volumes. The device width is thus reduced.



ROTOR

EVO-R Compact Air Handling Units are manufactured using new materials and manufacturing technologies. Thanks to high technology, heat transfer efficiencies reach 85% in heating and cooling seasons. The stepping motor used as a rotor drive is suitable for automation and it provides optimum energy gain by changing the number of revolutions according to the heating and cooling needs. The stepper motor used provides up to 55% energy savings over conventional AC motors.

The part where the rotor rotates and the heat is transferred is called the matrix and it is formed by wrapping the high strength aluminum sheets with each other by giving a wave form.

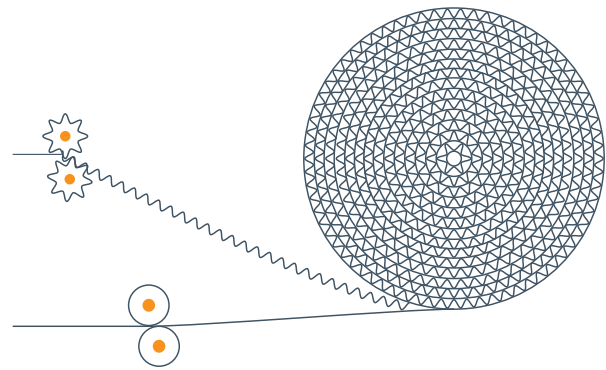

As well height (gap between wraps) increases, the amount of heat transfer and pressure drop is reduced. The decrease in well height increases the transfer of heat and pressure drop. In EVO-R Compact Air Handling Units, condensing type rotors with a 1.6 mm well height are used as standard. For higher heat transfer requirements, rotors with 1,4 mm well height can be selected from the selection software ,well heights of 1,8mm, 2,0mm and 2,5mm are available for lower pressure drop requirements.

Rotors are produced in three different types by changing the matrix material used to meet different moisture transfer needs

- **CONDENSING** Aluminum material
- **ENTHALPIC** Silica gel coated aluminum material
- **SORPTION** Zeolite coated aluminum material

The table below shows the heat and moisture transfer efficiencies of these three materials at different blwell heights.

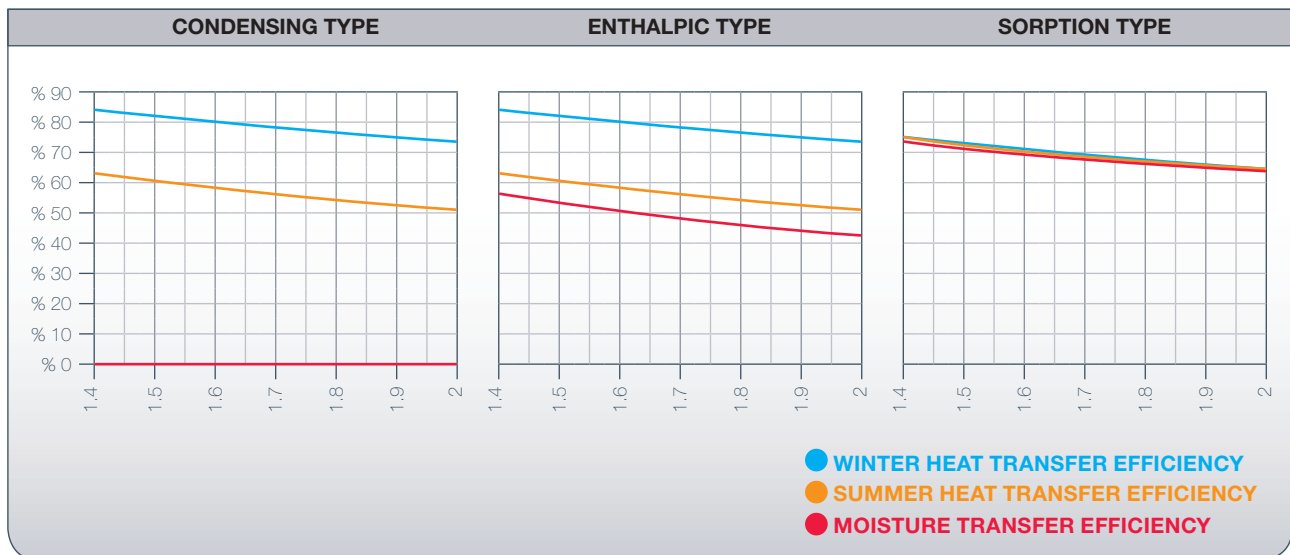

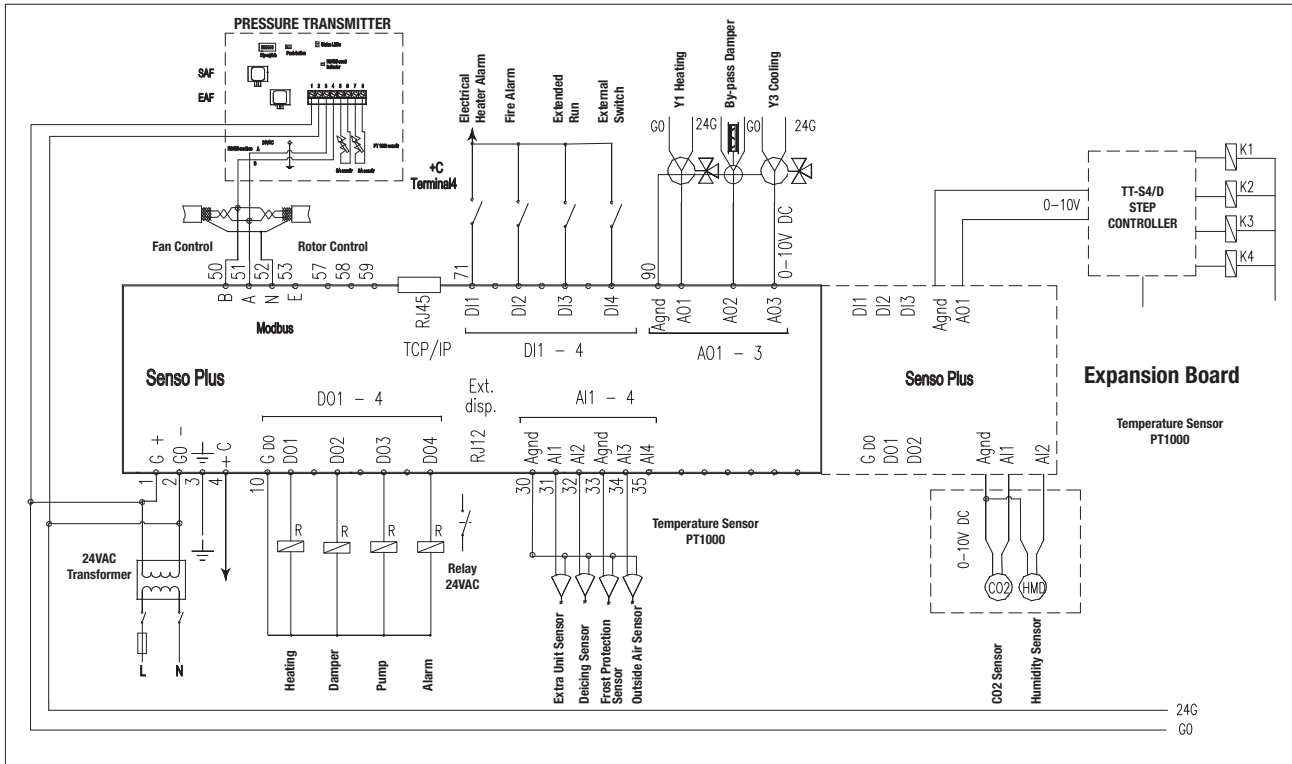

The advanced control system SENSO PLUS in EVO Compact Air Handling Units, provides the most efficient control of all components which can be installed internally and as external accessories, ensuring the desired airflow conditions.

Electrical Pre-Heater

Electric heaters in EVO Compact Air Handling Units are used for preheating fresh air from the outside for protecting the heat exchanger from freezing. With SENSO PLUS control, electric heaters are driven in 7 steps according to the desired set temperature and energy saving is ensured. All of the safety and operating equipment required by the electric heater is supplied standard with the SENSO PLUS control.

Heating Coil

Heating coils are used for increasing the supply air temperature and for bringing the supply air to the desired temperature after dehumidifying process. Hot water coils can be driven by proportional control via 2 or 3 way valves. With the SENSO PLUS control, frost protection mechanism is available as standard to prevent the temperature of the supply water from reaching freezing conditions in extreme cold climates. If the return water temperature falls below a certain value set on the control, the heating valve is switched to the 100% open position and a run signal is sent to the heating water circulation pump. If the temperature still does not rise to the desired value, the device is stopped and the user is given a freeze alarm.

Cooling Coil

Externally mounted duct-type water cooling coils are used for such purposes as lowering the blowing temperature and dehumidifying the air in the units. It can be driven either proportionally or by on / off method.

DX Coil

Externally mounted duct type DX batteries are used for purposes such as lowering the supply air temperature, dehumidifying process and bringing the blown air to the desired temperature after dehumidification. It can be step controlled with on / off method, maximum 8 step setting is available.

Constant flow control

To meet the desired constant airflow requirement in the EVO Compact Air Handling Units, the SENSO PLUS control measures the air pressure drop in the suction ports of the fans and compares the air flow with the set value to produce a working signal that will change the EC fan fan speed.

Contamination of the filters can be controlled by static flow control within the fan operating curve, to the static pressure requirements of the unit which result in higher or lower than the project values.

Constant Pressure Control

In EVO Compact Air Handling Units, constant pressure control is used to meet the variable airflow requirement of the air duct system. The SENSO PLUS control generates a working signal that will change the EC fan speed by continuously measuring the static pressure created in the supply air duct and comparing it with the value defined in the system. When a VAV damper opens or closes, higher or lower external static pressure needs can be met with constant pressure control within the fans operating curve. This way extreme noise in the ducts, unbalanced airflow distribution in different volumes is prevented.

Indoor Air Quality Control

The air quality sensor or the CO₂ sensor, which is placed in the critical volume or return channel in the interior, continuously measures the air quality. This value generates a signal that will change the EC fan fan speed by comparing it to the set point on the controller. If the indoor air quality is lower than the desired value, the fan speed and thus the fresh air amount is increased; if the indoor air quality is higher than the desired indoor air quality, the fan speed and fresh air speed are decreased; Energy saving is achieved in considerable amounts in heating or cooling loads caused by fresh air.

By-Pass Ventilation

In EVO-C Air Handling Units there is a by-pass damper in order to be able to deliver the outside air directly into the exchanger without entering the heat exchanger under suitable weather conditions. The SENSO PLUS control uses temperature sensors to determine when the by-pass will be turned on and off. This function, also known as Free Cooling, saves energy by opening the by-pass dampers when the outside air is suitable.

Rotary Heat Exchanger Control

In EVO R air handling units, rotary heat recovery exchanger is produced with a variable revolution rotor drive with SENSO PLUS control. By controlling the supply air temperature, the rotor revolution is automatically adjusted according to the required heat recovery. If the outside air conditions are appropriate, the rotor is stopped and free cooling is performed. An alarm signal is sent and the user is warned by the sensor attached to the device if the rotor does not rotate due to any malfunction. If the rotor is not spinning for 30 minutes due to suitable outdoor conditions, rotor will turn for 20 seconds at 12 rpm for automatic cleaning.

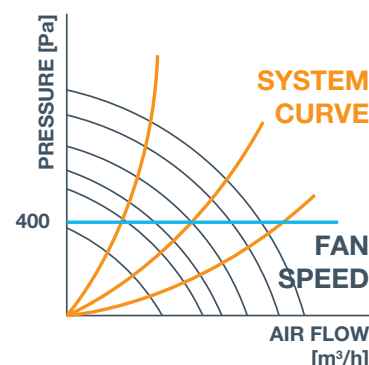
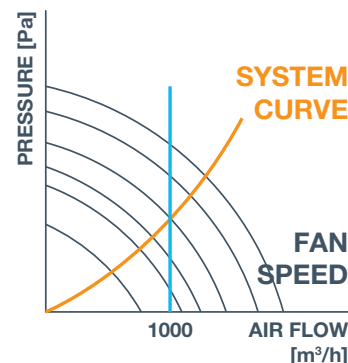

FILTERS

The pressure drops of the filters used to clean the air, can be controlled by SENSO PLUS control. Users are notified about the filter cleaning and replacement intervals. Pressure drop control can be made according to a constant pressure drop (Static) or variable air flow (Dynamic). Especially with units designed with variable speed fans, Dynamic Filter Control enables filter service at the right time.

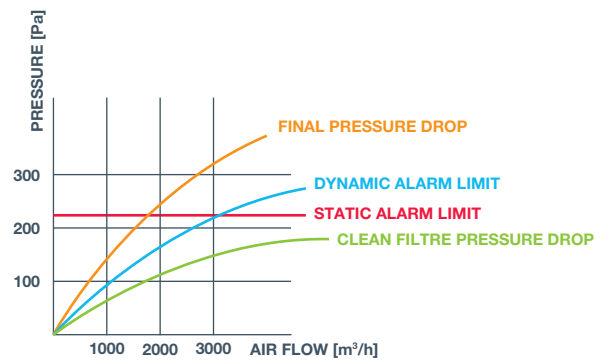

HUMIDITY CONTROL EQUIPMENT

Humidity control equipments are used to raise or lower the humidity of the supply air. With the SENSO PLUS control, the humidifier / de-humidifiers can be controlled to bring the supply air to the desired humidity value.

The SENSO PLUS control also provides system control besides equipment control, which means that the devices can be operated with the Yearly Timer Function according to the working periods: Daily, Weekly, Monthly or Yearly. In the Timer Function, values such as weekly working days, vacation times, daylight savings time can be defined and reported retrospectively.

Besides, the Support Function which is used to prevent the undesired conditions from occurring indoors even when the device is not working. The indoor temperature from falling below or exceeding a certain value even during non-working hours is ensured.

COMMUNICATION OPTIONS

SENSO PLUS control supports all of the universal communication protocols and interacts with other air handling units as well as with other building automation systems. ModBUS, BACnet and EXOline protocols are open as standard and there is also possibility to connect with LONWORKS protocol as an option.



ROOM CONTROL PANEL

With SENSO PLUS control, a standard control panel with a keypad as a user interface is delivered, optionally touch screen user interfaces are available as well. There is also a web server embedded in the card for monitoring and controlling the device through a computer. Settings for the controller can be done over the server, instantaneous operating values of the unit can be seen, as well as retroactive working values can be followed.



WEB INTERFACE (CLOUD CONTROL)

SENSO PLUS control connects the web server over the internet and allows you to view and change the settings of your unit on any computer / tablet or mobile phone anywhere in the world. No need for complicated network settings, only a connected network cable is enough. With this feature, it is possible to monitor and control all units from different projects on a single screen, so that all of the operating values, active alarms, settings can be observed and remotely changed. Cloud control is an option provided with SENSO PLUS, which is especially convenient when it is important to serve multiple devices within seconds, in different projects all around the world.

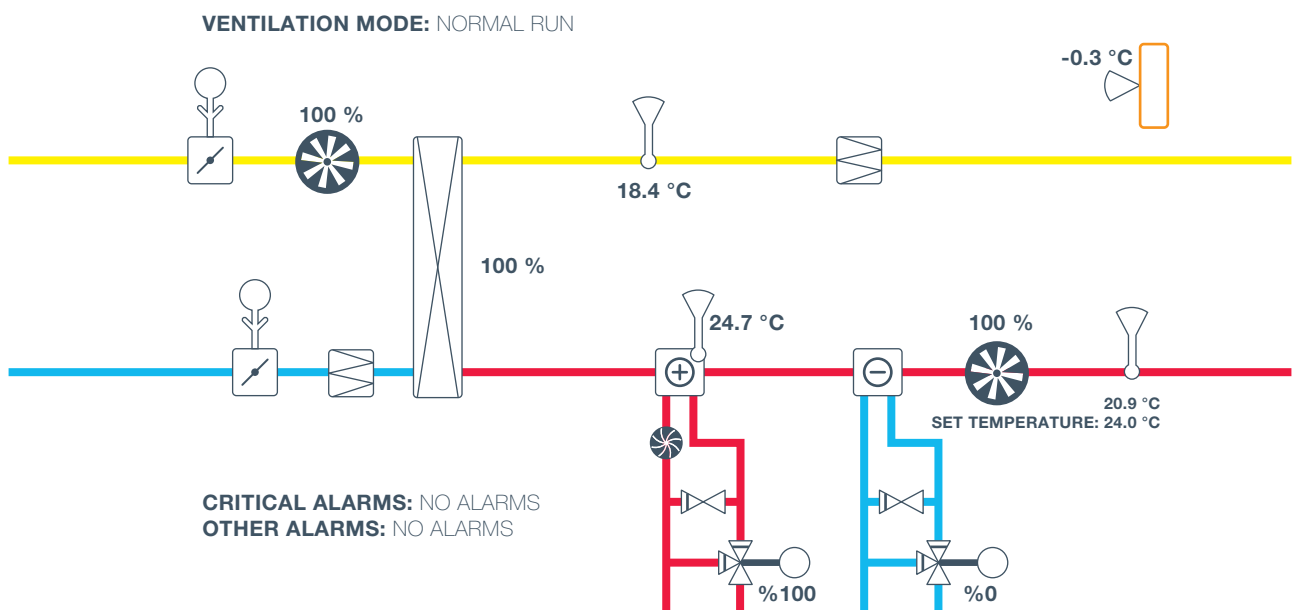

SENSO PLUS KONTROL SİSTEMLERİ

UNIQUE ADVANTAGES OF SENSO PLUS CONTROLS

- TCP / IP connection: The integrated web control console provides platform-independent remote monitoring and setting.
- Tablet, PC, smartphone provides you with 24/7 accessibility to your unit.
- BACNet, Modbus, EXOline, LON and CLOUDigo communication ports provide easy integration into all automation systems.
- With the modular structure, components in the unit can be added or deactivated after the installation.
- It provides a quick and easy configuration program from the computer and ease of operation with plug-and-play logic.
- Energy is saved;
 - By providing fresh air as much as the volume needed, it optimizes the air conditioning load resulting from fresh supply air.
 - Runs all components at their optimum points to achieve the desired supply temperature.
 - It optimizes the heat recovery operation according to indoor and outdoor weather conditions, provides free cooling at appropriate temperatures.
 - Provides filter service by constantly observing the pressure drops over the filters and informing the user accordingly.
- It provides instant information about problematic components with advanced alarm signals.
- All components of the control are supplied from a single point, so they fit perfectly and work seamlessly.
- The optional CLOUDigo platform; The system, which allows you to extend and is designed with maximum convenience, is ready to use when you plug in an ethernet cable. All devices using the SENSO PLUS control system can be viewed and controlled from a single screen.
- The devices continuously send data to the system and the data are recorded. Reports on energy efficiency can be generated by analyzing detailed data within specific dates.

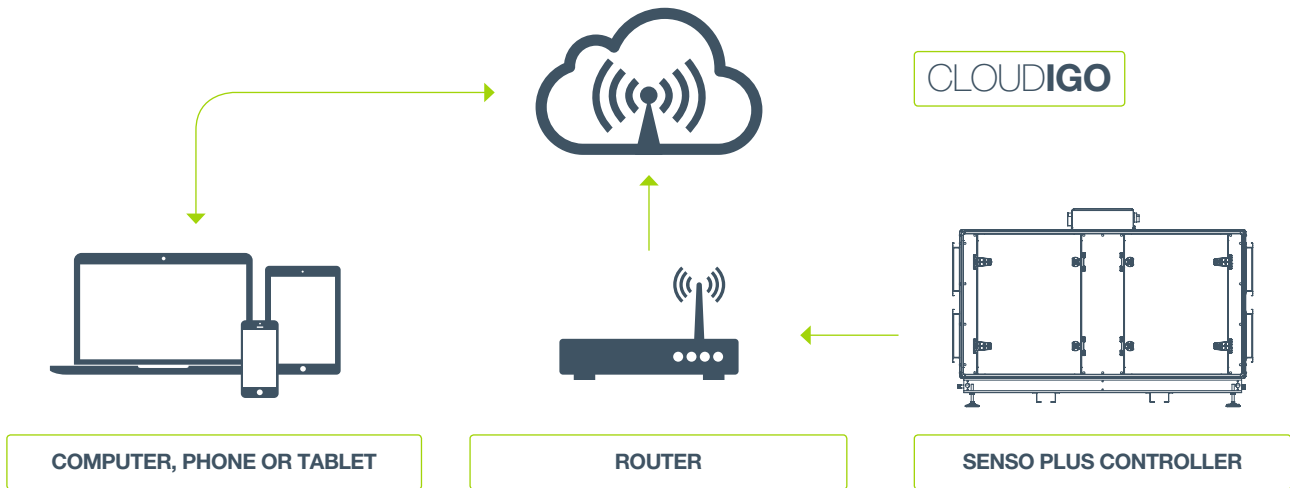

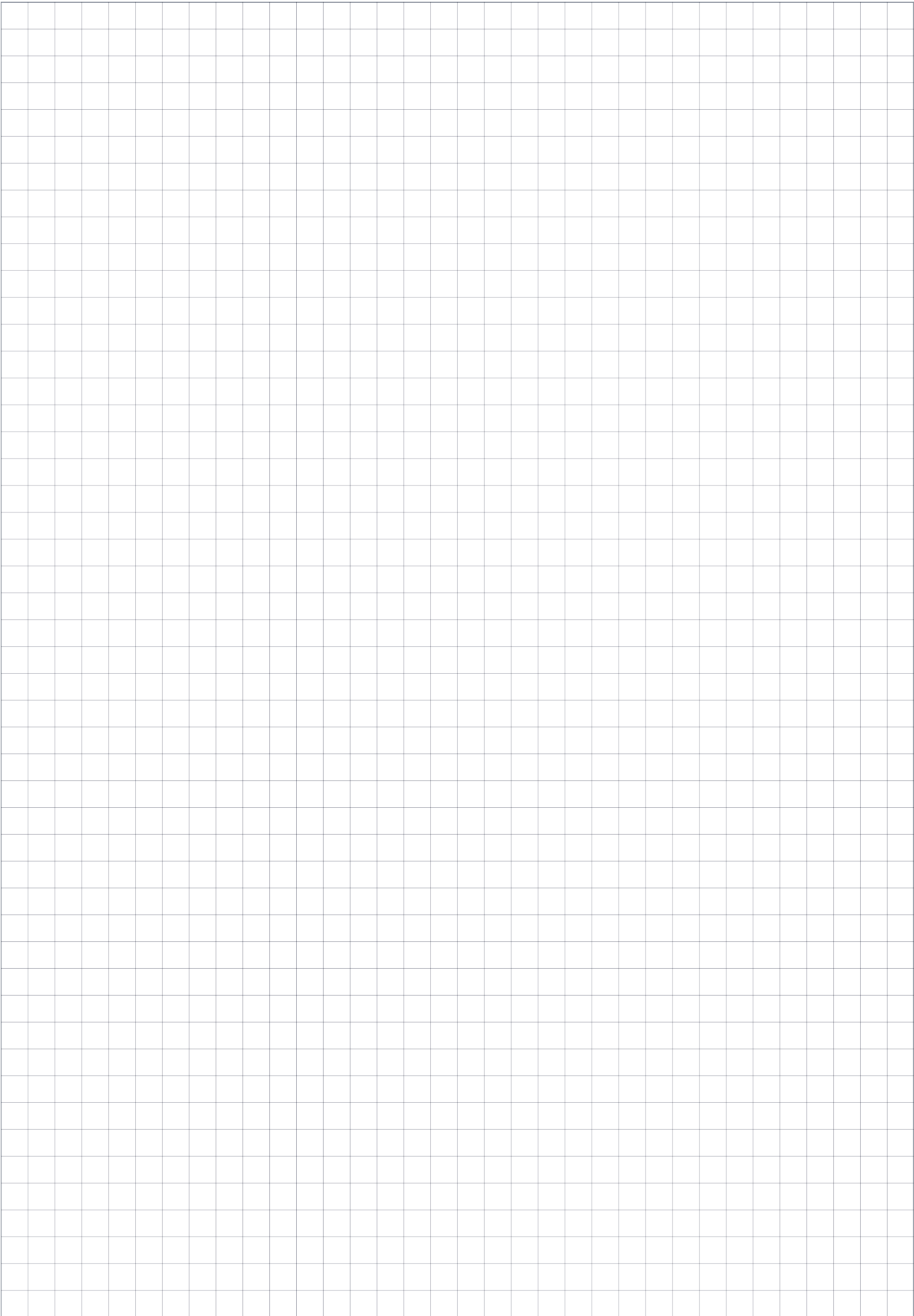

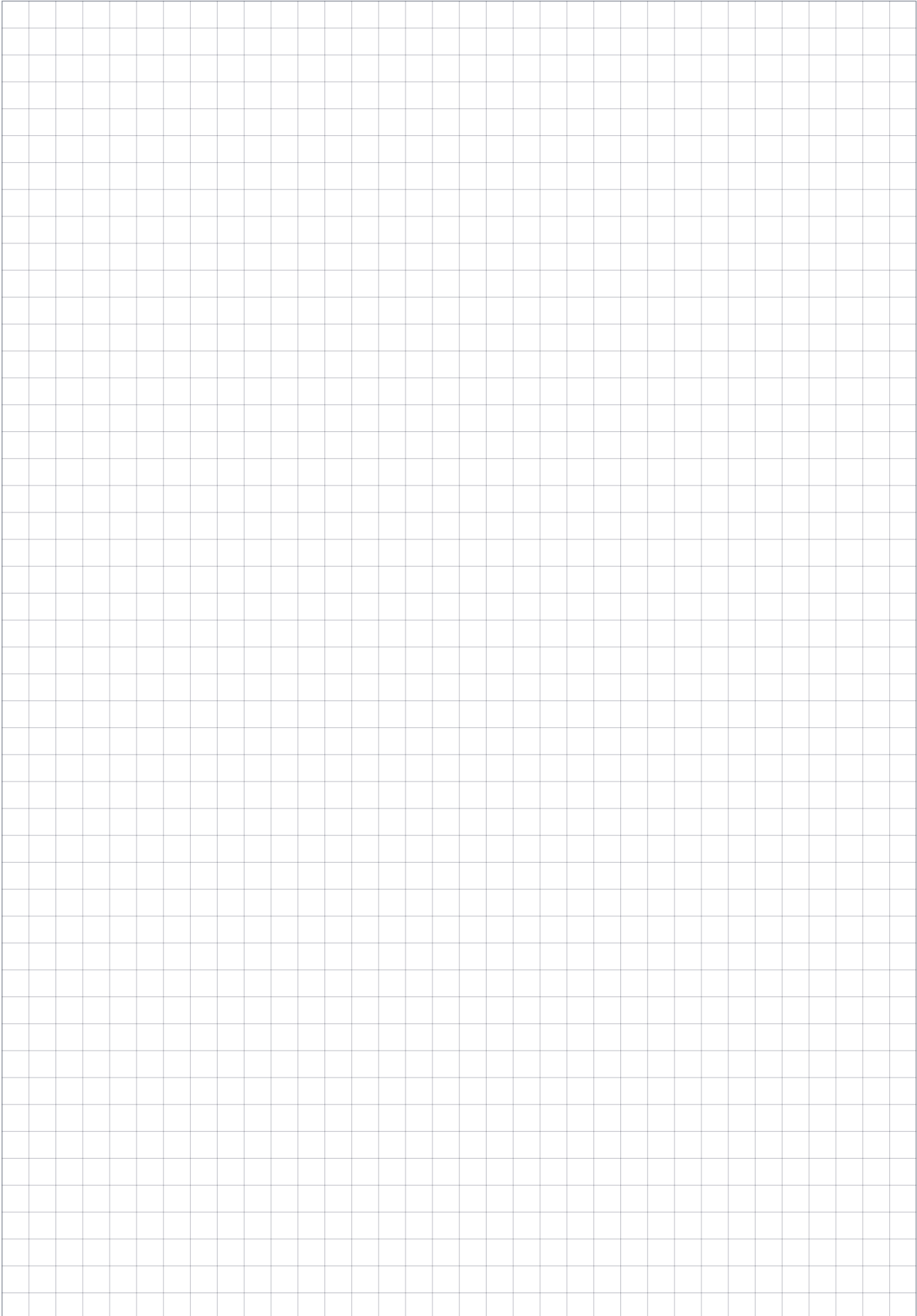



JUNE 2017 -- THE MANUFACTURER RESERVES THE RIGHT TO CHANGE THE SPECIFICATION WITHOUT PRIOR NOTICE.





AERA İKLİMLENDİRME TEKNOLOJİLERİ SAN. VE TİC. AŞ

SALES OFFICE ■ Varyap Meridian, Grand Tower A Blok No:89 Ataşehir, İSTANBUL - TR
TEL +90 216 504 76 86 FAX +90 216 504 76 90

FACTORY ■ 3. Cadde No:13 Pancar OSB, Torbalı, İzmir - TR
TEL +90 232 799 0 111 FAX +90 232 799 01 14

R&D CENTER ■ 3. Cadde No:13 Pancar OSB, Torbalı, İzmir - TR

aera.com.tr

