

MENUMASTER[®]

Commercial



Models RMS510DS and RMS510DSU shown with dial controls

Dial Control Models

- RMS510DS
- RMS510DSU

Value Line | Low Volume This category of microwave is ideal for...

Applications:

- Vending
- Break rooms
- Espresso bars
- Nurses stations

All ACP, Inc. commercial ovens are supported by our Culinary Center. Do not hesitate to contact us for any questions regarding food preparation, menu development and cooking times:
testkitchen@acpsolutions.com

Low Volume

Menumaster[®] Commercial Microwave RMS510DS & RMS510DSU, Dial Control Models

Power Output

- 1000 watts of power.
- Full power only for simple operation.

Certified Oven for Commercial Applications

- Tested to higher standards for a commercial rating —required by most commercial insurance policies and health inspectors.
- Interlock safety switch is tested to 4 times the standard of residential ovens.
- Constructed to withstand the foodservice environment, multiple users and variable ambient temperatures.
- Compared to a residential oven, this oven is more powerful for faster heating and better quality results.
- Engineered for a simple, “self-service” operation.

Easy to Use

- User friendly dial timer designed for self-serve applications.
- 6 minute digital timer lights up for “at-a-glance” monitoring.
- Timer automatically resets to zero if door is open during heating.
- See-through door and lighted interior for monitoring without opening the door.
- 23 liter (0.8 cubic foot) capacity accommodates a 305mm (12”) platter, prepackaged foods and single servings.

Easy to Maintain

- Stainless steel exterior wrap, door, and oven interior for increased durability.
- Sealed in ceramic shelf for easy cleaning.

Service

All products are backed by the ACP, Inc.
24/7 ComServ Support Center

MenuMaster® Commercial RMS510DS & RMS510DSU with Dial | Low Volume

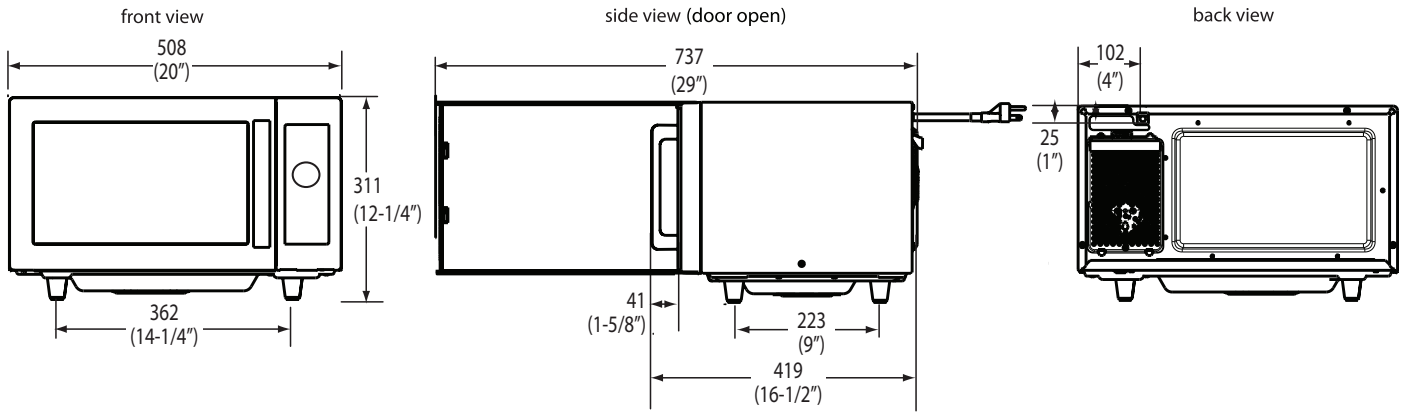

Drawings available from KCL CADlog - techs@kclcad.com

Dimensions			
Exterior	H 311 (12 1/4")	W 508 (20")	D** 419 (16 1/2")
Cavity	H 197 (7 3/4")	W 330 (13")	D 330 (13")
Usable Cavity Space	23 liter (0.8 cubic ft.)		
Door Depth	737 (29"), 90°+ door open		
Installation Clearances	Top: 305 (12")	Sides: 25 (1")	Back: None
Shipping Carton	H 381 (15")	W 584 (23")	D 457 (18")
Weight			
Product Weight	Ship weight (approx.)	UPS Shippable	
13.6 kg. (30 lbs.)	16.8 kg. (37 lbs.)	Yes	

Features	
Configuration	Countertop
Stackable	No
Display	LED
Control System	Dial
Programmable Control	N/A
Braille	No
Settings Programmable	N/A
Max. Cooking Time	6:00
Microwave Distribution	Rotating stirrer, bottom
Power Levels	1
Defrost	No
Time Entry Option	Yes
Multiple Portion Setting	No
Stage Cooking	1 stage
Interior Light	Yes
Automatic Voltage Sensor	No
Air Filter	No
Signal	End of cycle
Door Handle	Grab & Go
Exterior Finish	Stainless steel
Interior Finish	Stainless steel

Warranty

Warranty Certificate for this product can be found on the ACP, Inc. website at: www.acpsolutions.com/warranty.



Safety and Sanitation

This ACP, Inc. product meets and exceeds safety and sanitation standards set for commercial microwave ovens by UL, ETL, NSF, CSA, FDA, ETL EU (CB Scheme), CE, and TUV



Electrical Configuration									
Region	Model#/UPC	Power Consumption	Power Output	Power Source	Plug Configuration	Cord Length	Frequency	Magnetron	
EMEA, SEA, LATAM <i>single phase</i>	RMS510DS 728028316001	1500 W, 7.3 A	1000 W* Microwave	230V, 50 Hz, 16 A single phase	CEE 7/7 "Schuko"	1.5m (5 ft.)	2450 MHz	1	
EMEA (UK), SEA <i>single phase</i>	RMS510DSU 728028423150	1500 W, 7.3 A	1000 W* Microwave	230V, 50 Hz, 13 A single phase	BS1363/A	1.5m (5 ft.)	2450 MHz	1	

Measurements are millimeters. Measurements in () are US Standard

* IEC 60705 Tested

** Includes handle

EMEA = Europe, the Middle East and Africa; SEA=South East Asia; LATAM=Latin America

MENUMASTER[®]

Commercial



Model RCS511DSE shown

Medium Volume

This category of microwave is ideal for...

Applications:

- Coffee shops
- Ethnic restaurants
- Concessions
- Dessert stations

All ACP, Inc. commercial ovens are backed by our Culinary Center. Call us with any question regarding food preparation, menu development and cooking times. 866-426-2621.

Medium Volume

Menumaster Commercial Microwave Model RCS511DSE

Power Output

- 1100 watts of power.
- Four power levels.

Easy to Use

- User friendly ten minute dial timer.
- Timer automatically resets to zero if door is opened during heating. User option allows manual reset to zero.
- See-through door and lighted interior for monitoring without opening the door.
- 34 Liters (1.2 cubic ft.) capacity accommodates a 356 mm (14") platter, prepackaged foods and single servings.
- Stackable to save valuable counter space.

Easy to Maintain

- Stainless steel exterior and interior for easy cleaning and a commercial look.
- Constructed to withstand the foodservice environment.
- Non-removable air filter protects oven components.



Intertek

MenuMaster Commercial Microwave Model RCS511DSE | Medium Volume

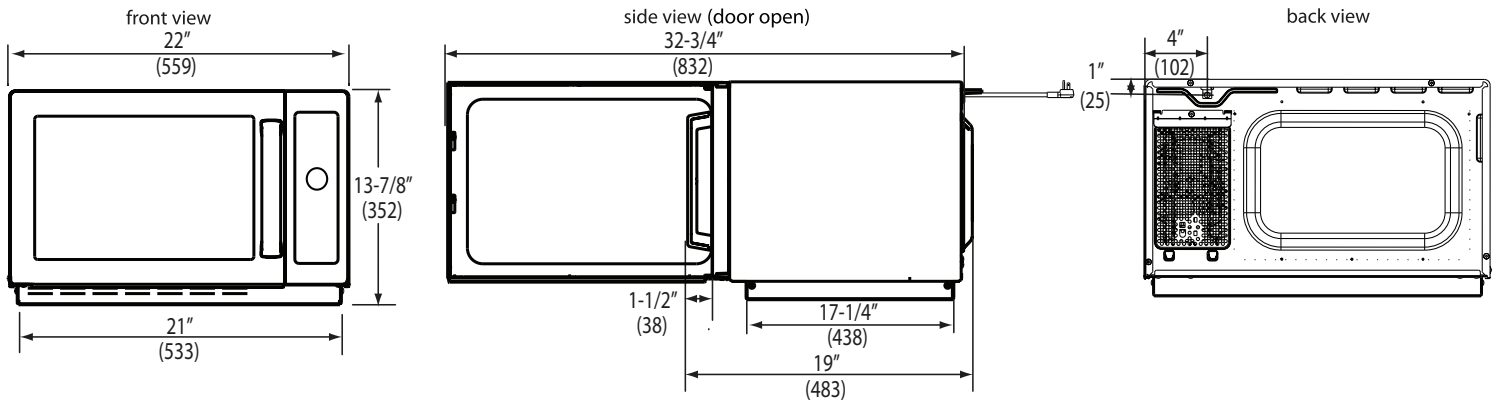

Installation Clearances - Top: 7" (178), Sides: 1" (25), Back: None

Specifications			
Model	RCS511DSE	UPC Code 728028129489	
Configuration	Countertop		
Control System	Dial		
Max. Cooking Time	10:00		
Power Levels	4		
Time Entry Option	Yes		
Microwave Distribution	Rotating antenna, top		
Magnetron	1		
Stackable	Yes		
Stage Cooking	1		
Interior Light	Yes		
Door Handle	Grab & Go		
Signal	End of cycle		
Exterior Dimensions	H 352 (13 7/8")	W 559 (22")	D*483 (19")
Cavity Dimensions	H 216 (8 1/2")	W 368 (14 1/2")	D 381 (15")
Door Depth	832 (32 3/4"), 90°+ door open		
Usable Cavity Space	34 Liters (1.2 cubic ft.)		
Exterior Finish	Stainless steel		
Interior Finish	Stainless steel		
Power Consumption	1600 W		
Power Output**	1100 W** Microwave		
Power Source	230V, 50 Hz, 16 A single phase		
Plug Configuration / Cord	CEE 7/7 "Schuko"	1.5 m (5 ft.)	
Frequency	2450 MHz		
Product Weight	19 kg (42 lbs.)		
Ship weight (approx.)	21 kg (47 lbs.)		
Shipping Carton Size	H 422 (16 5/8")	W 640 (23 3/8")	D 502 (19 3/4")
UPS Shippable	Yes		

Specifications

Commercial microwave shall have a user-friendly 10 minute dial timer and an end of cycle audible signal. Timer shall automatically reset if the door is opened during heating with user option to manually reset to zero. There shall be a four power level and one cooking stage. Microwave output shall be 1100 watts distributed by one magnetron with a rotating top antenna to provide superior even heating throughout the cavity. Durable door shall have a tempered glass window and a grab and go handle with a 90°+ opening for easy access. An interior light shall facilitate monitoring without opening the door. The large 34 Liter (1.2 cubic ft.) cavity shall accommodate a 356 mm (14") platter. Interior ceramic shelf shall be sealed and recessed on oven bottom to reduce plate-to-shelf edge impact. Oven shall have a stainless steel exterior and interior and be stackable to save counter and shelf space. The air filter shall be permanently affixed to the front of the oven. Microwave oven shall comply with standards set by the U.S Department of Health and Human Services.



Intertek



Warranty

Warranty Certificate for this product can be found on the ACP, Inc. website at:

www.acpsolutions.com/warranty



Measurements are in millimeters

* Includes handle

** IEC 60705 Tested

MENUMASTER[®]

Commercial



Model RCS511TS shown

Medium Volume

This category of microwave is ideal for...

Applications:

- Pizza restaurants
- Casual dining
- Clubs
- Deli

Defrost:

- Defrosts most frozen food products

All ACP, Inc. commercial ovens are supported by our Culinary Center. Do not hesitate to contact us for any questions regarding food preparation, menu development and cooking times: testkitchen@acpsolutions.com

Medium Volume

Menumaster Commercial Microwave Model RCS511TS

Power Output

- 1100 watts of power
- Five power levels for consistent, delicious results for frozen, refrigerated and fresh foods - from the freezer to table in minutes.

Easy to Use

- Up to 100 programmable menu items simplifies cooking and ensures consistent results.
- Four stage cooking option for easy one-touch cooking.
- Multiple quantity pad calculates the proper cooking times for multiple portions.
- User friendly touch controls are easy to use.
- Time entry option for added flexibility.
- Digital display with countdown timer for simple operation and "at-a-glance" monitoring.
- Braille touch pads.
- See-through door and lighted interior for monitoring without opening the door.
- 34 Liter (1.2 cubic ft.) capacity accommodates a 356 mm (14") platter, prepackaged foods and single servings.
- Stackable to save valuable counter space.

Easy to Maintain

- Stainless steel exterior and interior for easy cleaning and a professional look.
- Non-removable air filter protects oven components.
- Constructed to withstand the foodservice environment.
- Backed by the ACP, Inc. 24/7 ComServ Support Center.

MenuMaster Commercial Microwave Model RCS511TS | Medium Volume

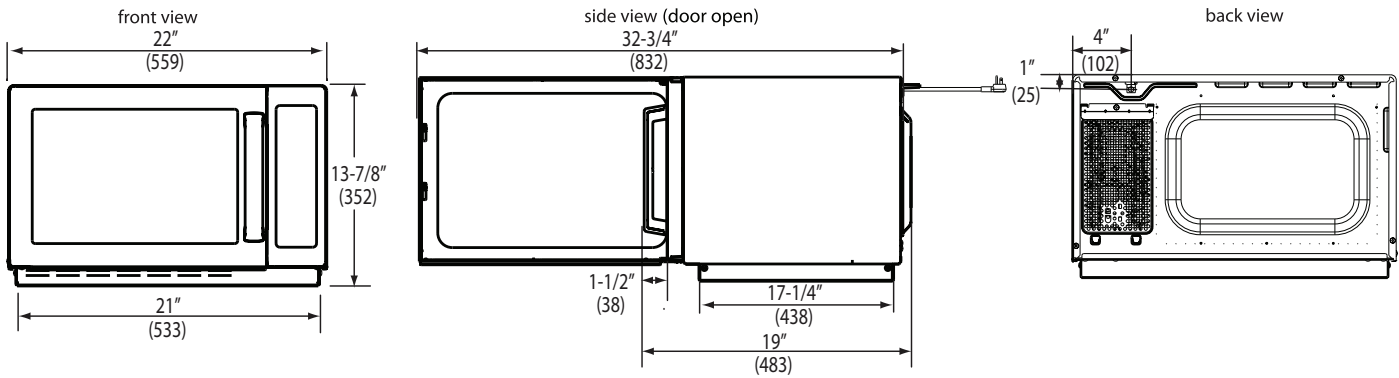

Installation Clearances - Top: 51 (2"), Sides: 25 (1"), Back: None

Specifications			
Model	RCS511TS	UPC Code 728028020762	
Configuration	Countertop		
Control System	Touch		
Programmable Control	10 pads		
Settings Programmable	100		
Max. Cooking Time	60:00		
Power Levels	5		
Defrost	Yes		
Time Entry Option	Yes		
Microwave Distribution	Rotating antenna, top		
Magnetron(s)	1		
Display	VFD		
Stackable	Yes		
Stage Cooking	Yes, 4		
Interior Light	Yes		
Door Handle	Grab & Go		
Signal	End of cycle, adjustable		
Air Filter	Non-removable with cleaning reminder		
Multiple Portion Setting	Yes, X2		
Exterior Dimensions	H 352 (13 7/8")	W 559 (22")	D*483 (19")
Cavity Dimensions	H 216 (8 1/2")	W 368 (14 1/2")	D 381 (15")
Door Depth	832 (32 3/4"), 90°+ door open		
Usable Cavity Space	34 Liters (1.2 cubic ft.)		
Exterior Finish	Stainless steel		
Interior Finish	Stainless steel		
Power Consumption	1600 W		
Power Output**	1100 W** Microwave		
Power Source	230V 50 Hz, 16 A single phase		
Plug Configuration / Cord	CEE 7/7 "Shuko" 1.5 m (5 ft.)		
Frequency	2450 MHz		
Product Weight	19 kg. (41 lb.)		
Ship weight (approx.)	21 kg (47 lb.)		
Shipping Carton Size	H 422 (16 5/8")	W 640 (25 3/16")	D 502 (19 3/4")
UPS Shippable	Yes		

Specifications

Commercial microwave 10 touch pad control panel shall be programmable with the ability to program up to 100 menu items with two multiple portions. Touch pad shall include Braille for ADA compliance. Cooking timer shall be 60 minute, countdown style with a time entry option and an adjustable end of cycle audible signal. There shall be 5 power levels, including defrost and 4 cooking stages. Microwave output shall be 1100 watts distributed by one magnetron with a rotating top antenna to provide superior even heating throughout the cavity. Durable door shall have a tempered glass window and a grab and go handle with a 90°+ opening for easy access. An interior light shall facilitate monitoring without opening the door. The large 34 Liter (1.2 cubic ft.) cavity shall accommodate a 356 mm (14") platter. Interior ceramic shelf shall be sealed and recessed on oven bottom to reduce plate-to-shelf edge impact. Oven shall have a stainless steel interior and exterior and be stackable to save counter and shelf space. Front air filter shall be permanently affixed to the front off the oven and have a clean filter reminder.

Safety and Sanitation

This ACP, Inc. product meets and exceeds safety and sanitation standards set for commercial microwave ovens by ETL EU and CE



Warranty

Warranty Certificate for this product can be found by locating it on the ACP, Inc. website at: www.acpsolutions.com/warranty



Service

All products are backed by our 24/7 ComServ Support Center.

Measurements are in millimeters

* Includes handle

** IEC 60705 Tested

MENUMASTER[®]

Commercial



Model RFS518TS shown

Medium Volume

This category of microwave is ideal for...

Applications:

- Pizza restaurants
- Casual dining
- Clubs
- Deli

Defrost:

- Defrosts most frozen food products

All ACP, Inc. commercial ovens are supported by our Culinary Center. Do not hesitate to contact us for any questions regarding food preparation, menu development and cooking times: testkitchen@acpsolutions.com



Medium Volume

Menumaster Commercial Microwave Model RFS518TS

Power Output

- 1800 watts of power.
- Five power levels for consistent, delicious results for frozen, refrigerated and fresh foods - from the freezer to table in minutes.

Easy to Use

- Up to 100 programmable menu items simplifies cooking and ensures consistent results.
- Four stage cooking option for easy one-touch cooking.
- Multiple quantity pad calculates the proper cooking times for multiple portions.
- User friendly touch controls are easy to use.
- Time entry option for added flexibility.
- Digital display with countdown timer for simple operation and "at-a-glance" monitoring.
- Braille touch pads.
- See-through door and lighted interior for monitoring without opening the door.
- 34 Liter (1.2 cubic ft.) capacity accommodates a 356 mm (14") platter, prepackaged foods and single servings.
- Stackable to save valuable counter space.

Easy to Maintain

- Stainless steel exterior and interior for easy cleaning and a professional look.
- Removable air filter protects oven components.
- Constructed to withstand the foodservice environment.
- ETL Listed.

MenuMaster Commercial Microwave Model RFS518TS | Medium Volume

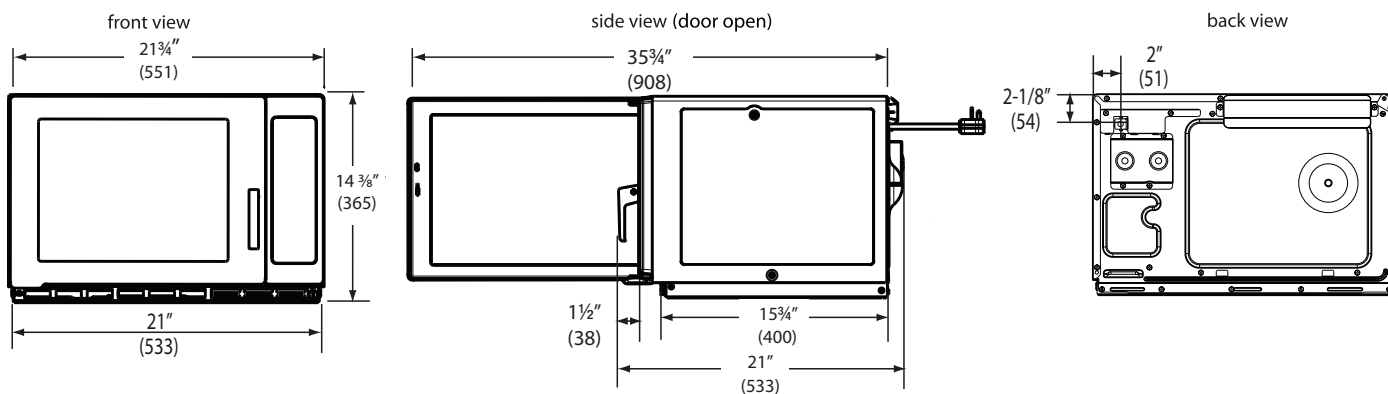

Installation Clearances - Top: 51 (2"), Sides: 25 (1"), Back: None

Specifications			
Model	RFS518TS	UPC Code 728028043181	
Configuration	Countertop		
Control System	Touch		
Programmable Control	10 pads		
Braille	Yes		
Settings Programmable	100		
Max. Cooking Time	60:00		
Power Levels	5		
Defrost	Yes		
Time Entry Option	Yes		
Microwave Distribution	Rotating antennas, top & bottom		
Magnetron(s)	2		
Display	LED		
Stackable	Yes		
Stage Cooking	Yes, 4		
Interior Light	Yes		
Door Handle	Pull Handle		
Signal	End of cycle, adjustable		
Air Filter	Removable with cleaning reminder		
Multiple Portion Setting	Yes, X2		
Exterior Dimensions	H 365 (14 3/8")	W 551 (21 3/4")	D* 533 (21")
Cavity Dimensions	H 226 (8 7/8")	W 359 (14 1/8")	D 413 (16 1/4")
Door Depth	864 (34"), 90°+ door open		
Usable Cavity Space	34 Liters (1.2 cubic ft.)		
Exterior Finish	Stainless steel		
Interior Finish	Stainless steel		
Power Consumption	2700 W, 12 A		
Power Output**	1800 W** Microwave		
Power Source	230V, 50 Hz, 16 A single phase		
Plug Configuration / Cord	CEE 7/7 "Schuko"	1.5 m (5 ft.)	
Frequency	2450 MHz		
Product Weight	32 kg. (70 lbs.)		
Ship weight (approx.)	35 kg. (78 lbs.)		
Shipping Carton Size	H 467 (18 1/2")	W 663 (26 1/8")	D 581 (22 7/8")

Specifications

Commercial microwave 10 touch pad control panel shall be programmable with the ability to program up to 100 menu items with two multiple portions. Touch pad shall include Braille for ADA compliance. Cooking timer shall be 60 minute, countdown style with a time entry option and an adjustable end of cycle audible signal. LED display shall be a backlit. There shall be 5 power levels, including defrost and 4 cooking stages. Microwave output shall be 1800 watts distributed by two magnetrons with rotating top and bottom antennas to provide superior even heating throughout the cavity. Durable door shall have a tempered glass window and a grab and go handle with a 90°+ opening for easy access. An interior light shall facilitate monitoring without opening the door. The large 34 Liter (1.2 cubic ft.) cavity shall accommodate a 356 mm (14") platter. Interior ceramic shelf shall be sealed and recessed on oven bottom to reduce plate-to-shelf edge impact. Oven shall have a stainless steel interior and exterior and be stackable to save counter and shelf space. Front air filter shall be removable and have a clean filter reminder.

Safety and Sanitation

This ACP, Inc. product meets and exceeds safety and sanitation standards set for commercial microwave ovens by ETL EU and CE



Warranty

Warranty Certificate for this product can be found by locating it on the ACP, Inc. website at: www.acpsolutions.com/warranty



Service

All products are backed by our 24/7 ComServ Support Center.

Measurements are in millimeters

* Includes handle

** IEC 60705 Tested